

IDM UID  
**8C49AE**

VERSION CREATED ON / VERSION / STATUS  
**15 Dec 2022 / 1.1 / Approved**

EXTERNAL REFERENCE / VERSION

**Technical Specifications (In-Cash Procurement)**

**Market Survey Technical Specifications for VV Bevel  
Repair**

Market Survey Technical Specifications for Bevel Repair

## Table of Content

<b>1</b>	<b>PURPOSE</b> .....	<b>3</b>
<b>2</b>	<b>SCOPE</b> .....	<b>3</b>
<b>3</b>	<b>DEFINITIONS</b> .....	<b>9</b>
<b>4</b>	<b>REFERENCES</b> .....	<b>11</b>
<b>5</b>	<b>CONTRACT EXECUTION</b> .....	<b>13</b>
5.1	Outline of Contract Implementation.....	13
5.2	Time Schedule.....	13
<b>6</b>	<b>EXPERIENCE AND PROFILE REQUIREMENTS</b> .....	<b>14</b>
<b>7</b>	<b>WORK DESCRIPTION</b> .....	<b>15</b>
<b>7.1</b>	<b>General description</b> .....	<b>15</b>
7.1.1	<i>Introduction of Vacuum Vessel Field Joint</i> .....	15
7.1.2	<i>VV Dimensional Data for Analysis</i> .....	16
7.1.3	<i>Repair type and scope</i> .....	17
<b>7.2</b>	<b>General requirement</b> .....	<b>21</b>
7.2.1	<i>Repair configuration</i> .....	21
7.2.2	<i>General repair sequence</i> .....	22
7.2.3	<i>Tolerance requirement</i> .....	23
<b>7.3</b>	<b>Scaffold for access</b> .....	<b>24</b>
<b>7.4</b>	<b>Protection for cleanliness</b> .....	<b>25</b>
<b>7.5</b>	<b>Build-up welding</b> .....	<b>25</b>
7.5.1	<i>Material and Welded Assembly Design Rules</i> .....	25
7.5.2	<i>Welding Processes</i> .....	25
7.5.3	<i>Welding Procedure Qualification (if applicable)</i> .....	25
7.5.4	<i>Filler material</i> .....	25
7.5.5	<i>Welder qualification</i> .....	26
7.5.6	<i>Repair welding execution</i> .....	26
7.5.7	<i>Visual and dimensional examination</i> .....	26
<b>7.6</b>	<b>Machining</b> .....	<b>26</b>
<b>7.7</b>	<b>Non-Destructive Examination</b> .....	<b>27</b>
7.7.1	<i>Surface examination</i> .....	27
7.7.2	<i>Volumetric examination</i> .....	27
7.7.3	<i>NDE for execution weld</i> .....	27
7.7.4	<i>NDE method</i> .....	27

7.7.5 *NDE Operators and Inspectors Qualification* .....28

**7.8 Dimensional inspection** .....28

**8 RESPONSIBILITIES** .....28

**9 LIST OF DELIVERABLES AND DUE DATES** .....29

**10 ACCEPTANCE CRITERIA**.....29

**11 SPECIFIC REQUIREMENTS AND CONDITIONS**.....30

**12 WORK MONITORING / MEETING SCHEDULE** .....30

**13 DELIVERY TIME BREAKDOWN**.....30

**14 QUALITY ASSURANCE (QA) REQUIREMENTS**.....30

**15 CAD DESIGN REQUIREMENTS (IF APPLICABLE)** .....30

**16 SAFETY REQUIREMENTS** .....31

**ANNEX A DETAIL INFORMATION ON DIMENSIONAL DEVIATIONS**.....32

**A-1 Sector 6 facing sector 7** .....32

**A-2 Sector 7 facing sector 6** .....35

**A-3 Sector 8 facing sector 7** .....39

**A-4 Sector 8 facing sector 9** .....42

**ANNEX B ALTERNATIVE PROPOSALS FOR REPAIR**.....45

## 1 Purpose

The purpose of this document is to provide a technical specification for the site repair of the field joint levels of the Vacuum Vessel sectors delivered to IO, The technical specification covers all repair required for the three delivered sectors on site (Sector 6, Sector 7, and Sector 8). Table 1-1 and Figure 1-1 show the repair area and configuration.

Table 1-1 Repair area and configuration

Sectors	Side A	Side B	Repair configuration
Sector 6	Facing S5	Facing S7	Vertical on SSAT for both side
Sector 7	Facing S6	Facing S8	Vertical on SSAT for both side
Sector 8	Facing S7	Facing S9	Horizontal configuration – after top side repair, the turning over of the sector is considered for opposite side repair (Vertical repair of opposite side may be considered as well)

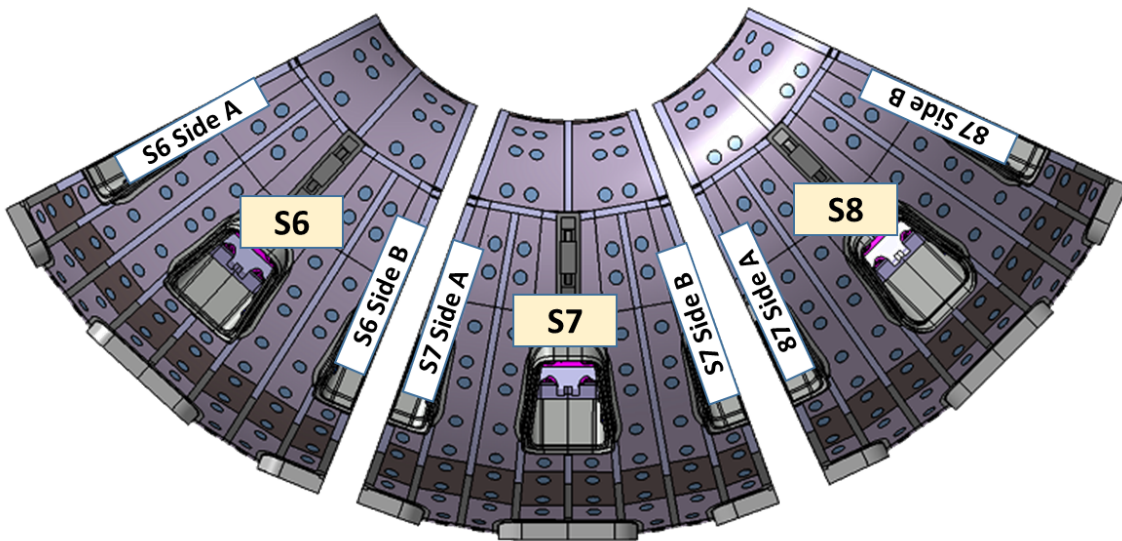


Figure 1-1 Top view of three sectors showing side A and B

## 2 Scope

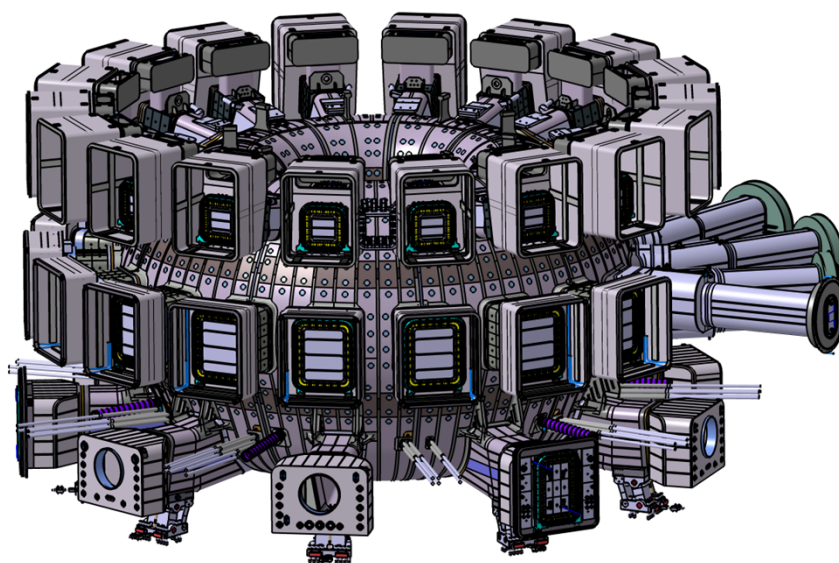
ITER is a large experimental Tokamak device being built to research fusion power and classified as INB174. The Vacuum Vessel (VV) is one of the most important and critical systems in the ITER project. The main components that make up the VV are the main vessel, the port structures and the VV supporting system, see Figure 2-1.

The VV is a torus-shaped double wall structure with shielding and cooling water between the shells. The basic vessel design is an all-welded stainless steel 316L(N) structure. Only the outer shell serves as the first plasma confinement barrier.

The ITER Vacuum Vessel is classified as level N2 category IV nuclear pressure equipment in accordance with French Order Dec 12 2005 concerning Nuclear Pressure Equipment. The items is designed and manufactured according to the code RCC-MR 2007 Subsection C for design and in conformity with specific requirements of the Order concerning Nuclear Pressure Equipment. As such the manufacturing is controlled an Agreed Notified Body contracted by IO. IO is the manufacturer of the VV assembly.

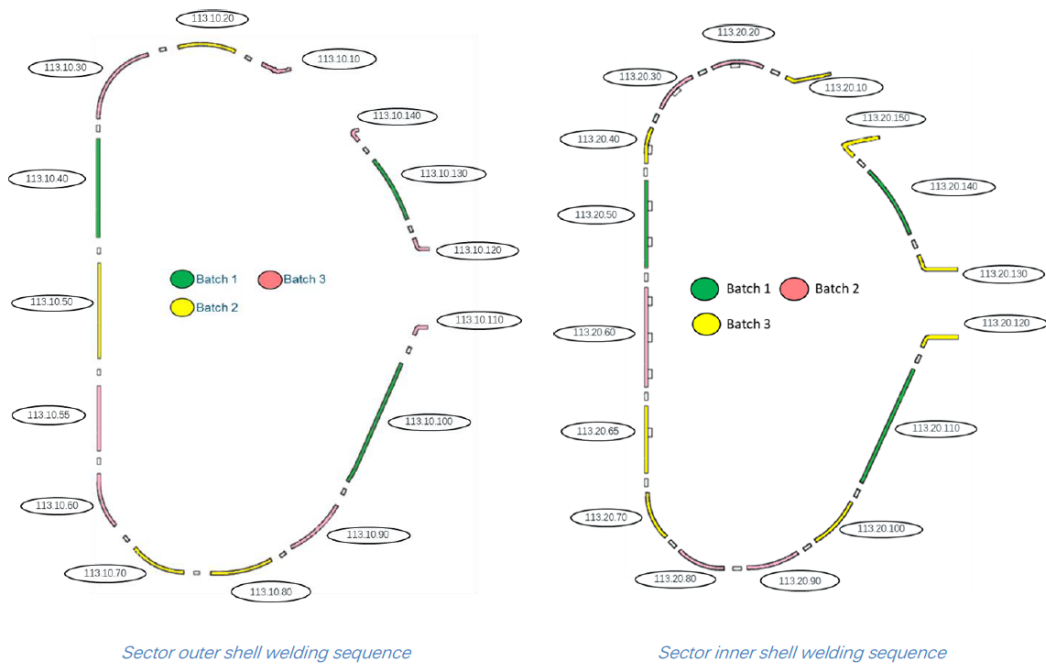
The VV is fabricated in different factories as 9 doubled wall Sectors each spanning 40°. Four of the sectors are fabricated by supplier of the Korean Domestic Agency, Hyundai Heavy Industries (HHI), three have already been delivered to ITER, Five are fabricated by the European Domestic Agency supplier, the consortium AMW (Ansaldo-Mangiarotti-Walter Tosto) there are currently in manufacturing stage.

Each of the sectors are assembled at the IO site together with VV Thermal Shields panels and two Toroidal Field (TF) coils to form a Sector Module (SM). After the sector modules are lowered into and positioned in the pit, nine Field Joints (FJ) will be welded using Splice Plates (SP) to compensate for the dimensional differences of the sectors and to complete the VV torus.

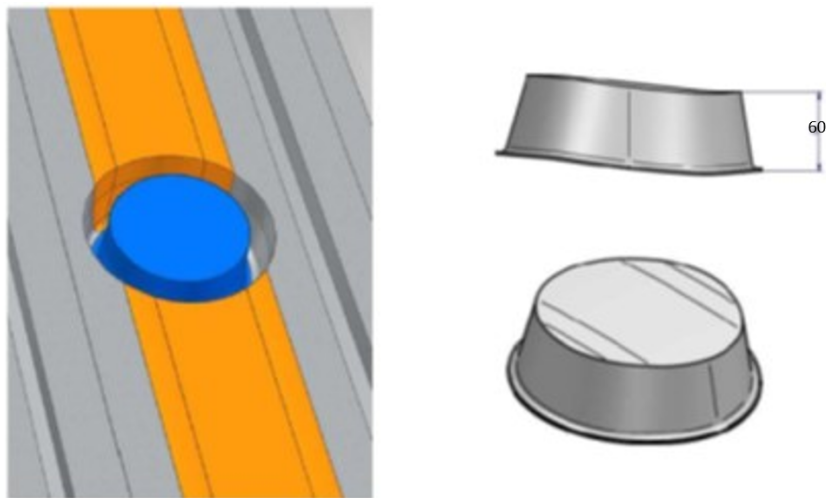


**Figure 2-1 General view of the Vacuum Vessel & Ports, VV Gravity Supports and In Viewing Lower Penetration & Divertor Pipes**

The gap and mismatch between the sectors will be measured and splice plates will be machined to fit prior to the welding. The splice plates are segmented into several segments and welded by batches. The next figure reflect the segmentation of the outer and inner splice plates, the colour code indicates the batches (Figure 2-2). The transitions between segment splice plates are covered by the so called biscuits (Figure 2-3).



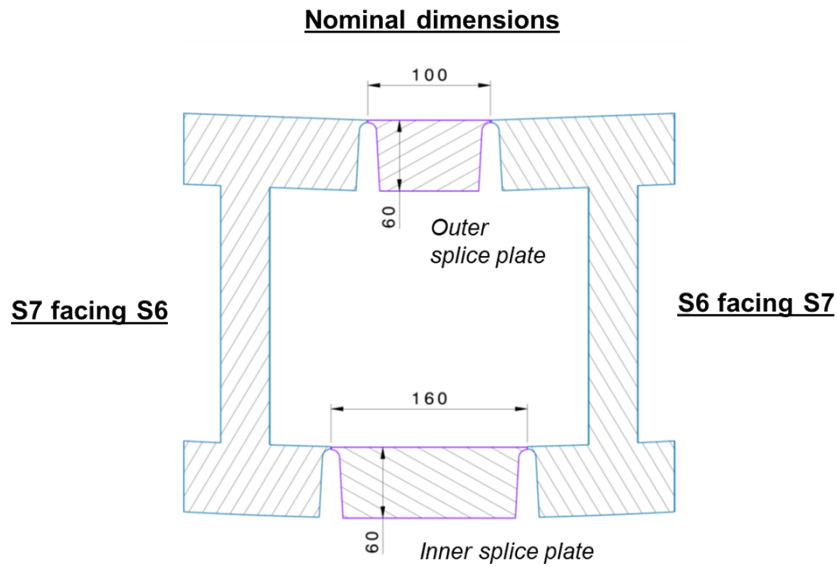
**Figure 2-2. Outer and inner splice plates segmentation**



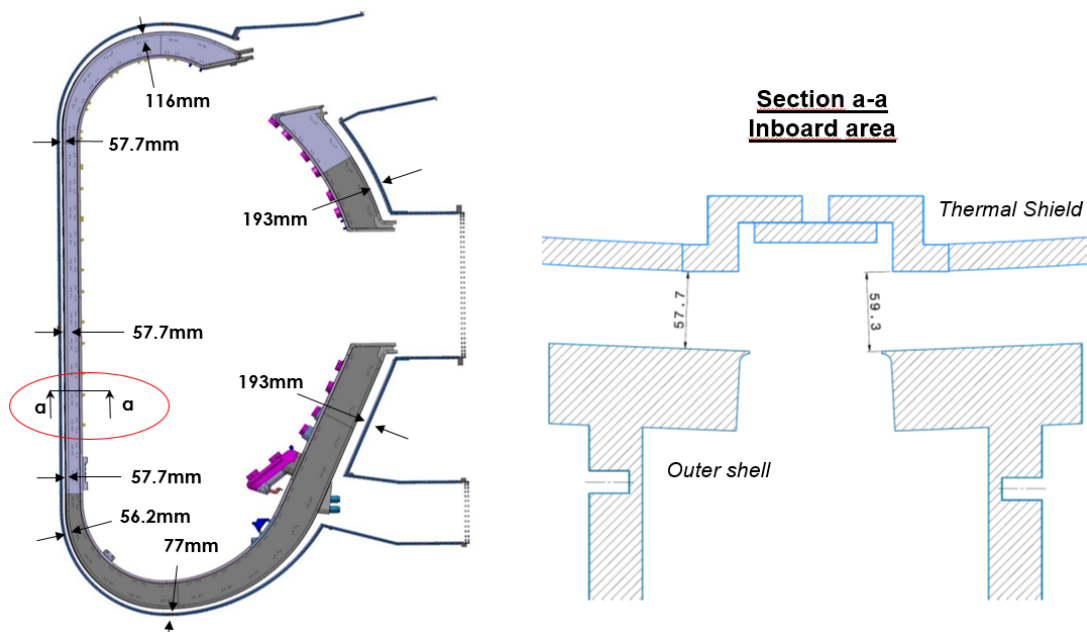
**Figure 2-3. Biscuits**

The welding of the field joints is constrained by the presence of the Thermal Shield (TS) behind the VV, which limits back access for the backing gas system and NDE operations. .

Figure 2-4 shows a representative cross-section of the field joint with the outer and inner splice plates in nominal configuration.



**Figure 2-4. Representative cross-section**



**Figure 2-5. Gap with Thermal Shield**

For this reason the baseline welding method chosen is narrow gap automated TIG (tungsten inert gas). ITER placed a contract to develop the welding procedures for the sectors with the company ENSA. Due to accessibility constraints, automatic welding tools were developed. Taking into account basic concepts as movement capacity and movement accuracy (accuracy, resolution,

repeatability, configuration, nominal load, robot dimensions and arm reach), ENSA chose Anthropomorphic Robotic Arms and Welding Heads, A maximum number of 3 robots are suitable to be used at the same time in the Tokamak pit taking into account the space availability inside the VV . The sequential welding also allows to face the shrinkage and distortion of the components while welding. Specific welding heads have been developed for sectors and other ones for ports. After the development phase it has been tested that it is possible to use both for sector welding. The distance between the inner and outer shells of the VV is not constant, being deeper in the outboard region. The following figure shows two different typical configurations of the weld head for reaching the outer shell bevels in the inboard and outboard areas.

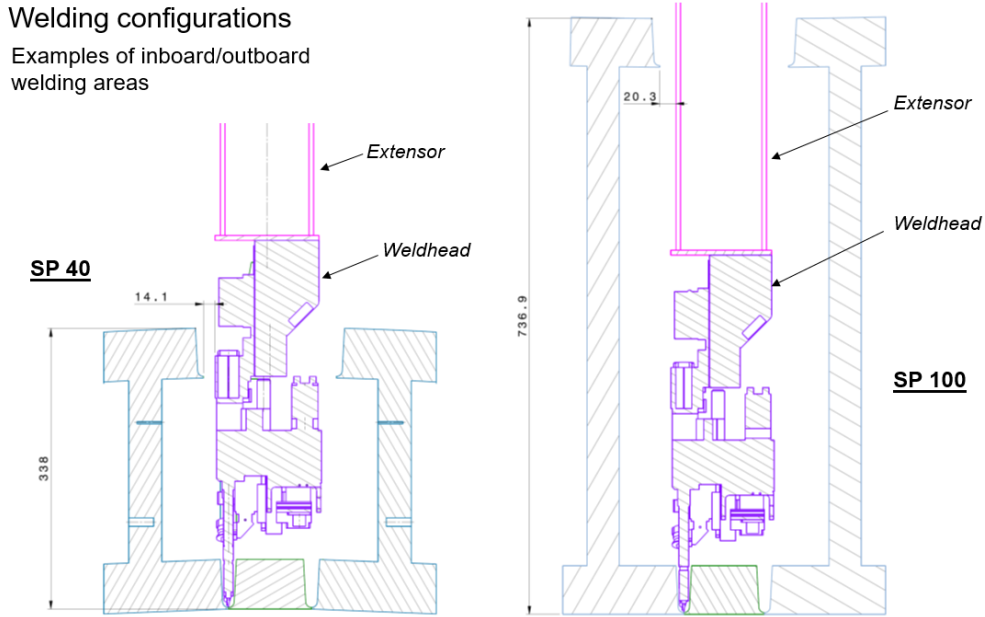


Figure 2-6. Automatic Welding Head nominal configurations

Automatic welding technology requires demanding manufacturing tolerances on the VV sector weld preparation, on the planarity of the perimeter , on the bevel angle and on the toe thickness.

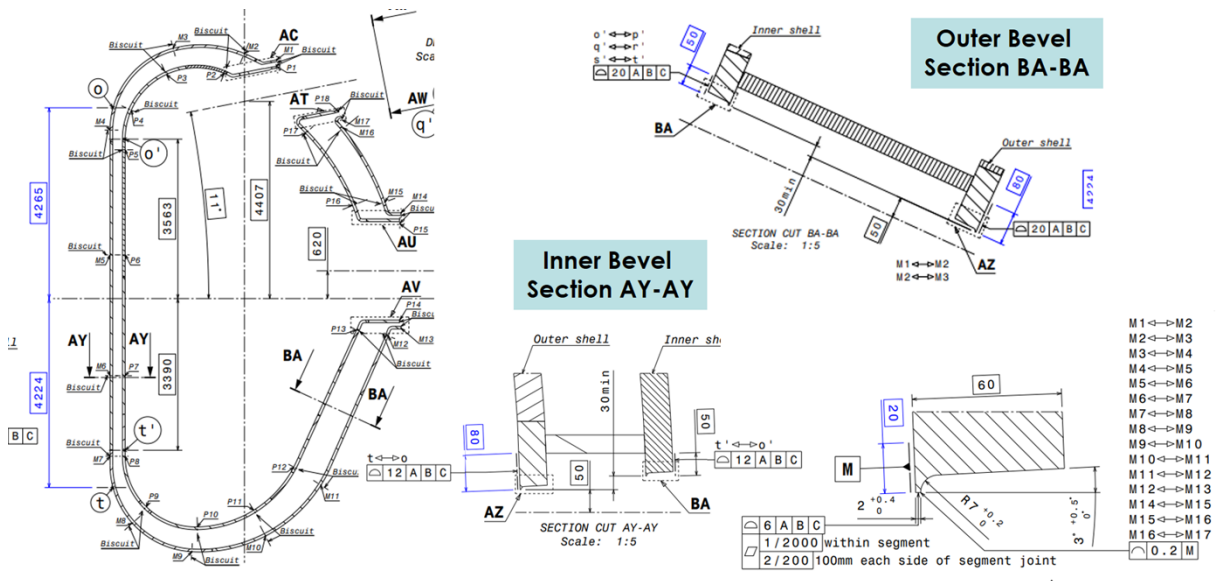


Figure 2-7. Tolerance requirements on VV Field Joint Bevels



The three sectors already delivered to IO were non-conform to the tolerance requirements required to perform automatic welding.

The Contractor shall perform the bevel repair of both sides of these three VV sectors according to requirements specified later on this specification. There are three kinds of site bevel repair which shall be considered in this specification.

- Type 1: Build-up welding by toroidal dimensional deviation
- Type 2: Root nose local grinding/machining or local build-up by thickness deviation
- Type 3: Machining by bevel angle deviation

IO has produced a risk analysis of performing this build-up. A demonstration coupon is ongoing to mitigate risk.

All repair specified in this specification is limited to outer shell. More information for repair scope and region to be repaired is described in Section 7 and Annex A.

Alternative solutions to repair the VV can be presented by the Contractor, under the condition that the target restored geometry is respected. For example for large deviations in the toroidal direction as the one assessed for the lower segment of Sector 8 (see Table 7.3 Splice Plates 60 to 100), an alternative to build-up with a strip plate butt welded to the sector edge may be considered. The non-conformities that are present on the delivered sectors are due non-mitigated welding shrinkage during the welding of the sectors by HHI. IO as the Manufacturer can sub-contract the repair activity to a different company than HHI.

The Authorized Notified Body of the VV ESPN has in principle no objection that other company than HHI will perform weld buildup on-site. Amongst the conditions that apply:

- Shop Qualification document shall describe the Organization and the related QA documentation, in particular in relation with welding & NDT activities.
- The scope of work of the subcontractor shall be clearly defined, i.e. who will update the as-built drawings & the 3D model, whether a separate Sector End of Manufacturing Report will be issued.
- If the performer works as subcontractor of HHI and applies the HHI QA system and the HHI technical documents, use can be made of the HHI demonstration/qualification work.
- If the performer works as subcontractor of IO and does not apply the HHI QA system or HHI technical documents, new demonstration/qualification work shall be done for the welding and NDT activities.

The Contractor is responsible for documents that shall be issued/approved before/after repair implementation;

- Before implementation
  - Quality Plan (QP)
  - Documentation for on-site work permit
  - Inspection and testing plan (ITP)
  - Dedicated repair procedure
  - Supporting procedures to be applied to related repair operation
  - Work Shop qualification report:

- Manual UT qualification
- Welding qualification and/or demonstration according to RCC-MR if needed
- After implementation
  - Final acceptance report
  - Final dossier

The Contractor is responsible for providing all necessary material and equipment for repair implementation:

- Filler material for build-up welding
- Scaffold for access
- Portable milling machining
- NDE equipment including consumables

The IO is responsible for providing necessary information to the contractor:

- As-built VV bevel CAD model reconstructed from 3D scanned data
- All other dimensional information of the non-conformity coming from FAT and SAT
- IO Analysis on dimensional deviation for information
- IO Risk Analysis of performing build-up
- Results of the demonstration coupon

The IO is responsible for handling activities of the VV sectors in the IO premises

### 3 Definitions

Here are the main terminology and acronyms used in this document:

ANB	Agreed Notified Body
ASN	French Nuclear Safety Authority (from French “Autorité de Sûreté Nucléaire”)
A&M	Alignment and Metrology
CAD	Computer Aided Design
CMM	Configuration Management Model
CODAC	Control, Data Access and Communication
DDD	Design Description Document
DMH	Dimensional Metrology Handbook
ESPN	Nuclear Pressurized Equipment (from French "Equipements Sous Pression Nucléaire")
FMEC	Failure Modes Effects and Criticality
HP	Hold Point
IAEA	International Atomic Energy Agency
ICD	Interface Control Document
IDM	ITER Document Management
IG	ITER Grade
IO	ITER Organization
IS	Interface Sheet
ISO	International Organization for Standardization

I&C	Instrumentation and Control
MIP	Manufacturing and Inspection Plan
MQP	Management and Quality Program
NP	Notification Point
PBS	Plant Breakdown Structure
PED	Pressure Equipment Directive
PFD	Process Flow Diagram
PIC	Protection Important Component
PR	Project Requirements
PS	Project Specifications
P&ID	Process and Instrumentation Diagram
QA	Quality Assurance
QCR	Quality Control Review
QP	Quality Plan
R	Review
RAMI	Reliability, Availability, Maintainability, Inspectability
RBD	Reliability Block Diagram
RH	Remote Handling
RPrS	Rapport Préliminaire de Sureté
RO	Responsible Officer
R&D	Research and Development
S	Surveillance Point
SDP	System Design Process
SEMP	System Engineering Management Plan
SIC	Safety Important Class
SRD	System Requirement Document
SR	Status Review
TA	Task Agreement
W	Witness Point

## 4 References

- [1]. Working Instruction for Manufacturing Readiness Review [ITER\\_D\\_44SZYP\\_v3.1](#).
- [2]. Procedure for management of Nonconformities [ITER\\_D\\_22F53X\\_v8.2](#)
- [3]. Procedure for the management of Deviation Request [ITER\\_D\\_2LZJHB\\_v8.1](#).
- [4]. End of Manufacturing Report content for Vacuum Vessel [ITER\\_D\\_TFLQEU\\_v2.2](#)
- [5]. ITER Vacuum Handbook (IVH) [ITER\\_D\\_29DFGH](#).
- [6]. Safety Important Functions and Components Classification Criteria and Methodology [ITER\\_D\\_347SF3\\_v1.8](#).
- [7]. Quality Classification Determination [ITER\\_D\\_24VOES\\_v4.3](#).
- [8]. RCC-MR 2007 subsection C (class 2)
- [9]. French Order dated 30 December 2015 on nuclear pressure equipment (ESPN)
- [10]. Pressure Equipment Directive 2014/68/EU
- [11]. French ASN Guide No. 8 (04/09/2012): Conformity Assessment of Nuclear Pressure Equipment
- [12]. EN 1993-1-8, Eurocode 3: Design of steel structures –
- [13]. ASME Section VIII, Division 1 and Division 2.
- [14]. DDD 1.5 Vacuum Vessel [ITER\\_D\\_22FPWQ\\_v4.0](#)
- [15]. ITER Standard Component Register [ITER\\_D\\_35UVAQ\\_v4.0](#)
- [16]. Material Approval Request [ITER\\_D\\_2MGWR4\\_v2.0](#).
- [17]. ITER Dimensional Metrology Handbook [ITER\\_D\\_46FN9B\\_v2.1](#)
- [18]. ITER Numbering System for Components and Parts [ITER\\_D\\_28QDBS\\_v5.0](#)
- [19]. ITER Requirements Regarding Contractors Release Note [ITER\\_D\\_22F52F\\_v5.0](#)
- [20]. Handover procedure for the VV components [ITER\\_D\\_TXDEW4\\_v2.2](#)
- [21]. ITER Procurement Quality Requirements [ITER\\_D\\_22MFG4\\_v5.1](#)
- [22]. Order dated 7 February 2012 relating to the general technical regulations applicable to BNI - FR [ITER\\_D\\_7GJHSE\\_v1.3](#) translated for guidance in Order dated 7 February 2012 relating to the general technical regulations applicable to BNI - EN [ITER\\_D\\_7M2YKF\\_v1.7](#) and the subsequent ASN decisions linked to this Order
- [23]. Procurement Requirements for Producing a Quality Plan [ITER\\_D\\_22MFMW\\_v4.0](#)
- [24]. Requirements for Preparing and Implementing a Manufacturing and Inspection Plan [ITER\\_D\\_22MDZD\\_v3.7](#)
- [25]. Requirements for DA / Supplier / Subcontractors Deviations & Nonconformities [ITER\\_D\\_22F53X\\_v8.2](#)
- [26]. Quality Assurance for ITER Safety Codes Procedure [ITER\\_D\\_258LKL\\_v3.1](#)
- [27]. Overall supervision plan of the chain of suppliers for Safety Important Components, Structures and Systems and Safety Related Activities [ITER\\_D\\_4EUQFL\\_v7.4](#)
- [28]. Internal Regulations [ITER\\_D\\_27WDZW\\_v3.1](#)
- [29]. Working conditions on the ITER Organization site [ITER\\_D\\_2EQ9JM\\_v2.0](#) (Obsolete)
- [30]. Health Protection and Safety General Coordination Plan - ITER Construction Site - Volume 0 - General Safety Rules [ITER\\_D\\_2NUEYG\\_v5.7](#)
- [31]. Procedure on procurement documentation exchange between IO, DAs and contractors [ITER\\_D\\_35BVQR\\_v5.0](#)
- [32]. ITER On-Site Testing Strategy [ITER\\_D\\_44U2Y4\\_v1.3](#) (Obsolete)
- [33]. Fluid and Processing Material Approval request [ITER\\_D\\_VH2KDW](#)
- [34]. Provisions for Implementation of the Generic Safety Requirements by the External Actors/Interveners [ITER\\_D\\_SBSTBM\\_v2.2](#)
- [35]. ITER Abbreviations [ITER\\_D\\_2MU6W5\\_v1.17](#)
- [36]. Procedure for ITER CAD Data Exchanges [ITER\\_D\\_2NCULZ\\_v3.1](#)
- [37]. CAD Manual 01 – Introduction [ITER\\_D\\_249WLQ\\_v7.0](#)
- [38]. Procedure for the CAD management plan [ITER\\_D\\_2DWU2M\\_v2.2](#)

- [39]. Specification for CAD data Production in ITER direct contracts [ITER\\_D\\_P7Q3J7\\_v2.0](#)
- [40]. CAD Manual 07 - CAD Fact Sheet [ITER\\_D\\_249WUL\\_v6.2](#)
- [41]. DCIF for Contract Lower Penetration Design and Manufacturing [ITER\\_D\\_Y5PMQT\\_v1.2](#)
- [42]. Engineered Complex Tools Generic Requirements; [ITER\\_D\\_VCQHTL](#)
- [43]. CAD data Requirement Summary for Contractor Supplied Data; [ITER\\_D\\_HPQ64Y](#)
- [44]. IO QA Deviation Request Template; [ITER\\_D\\_2LRNQP](#)
- [45]. DA/Supplier/Subcontractor QA Non-Conformance Report Template; [ITER\\_D\\_A6HRLB](#)
- [46]. The Site Signage & Graphics Standards; [ITER\\_D\\_4ALJEU](#)
- [47]. Work at Height; [ITER\\_D\\_6TT3CX](#)
- [48]. Safe Access for Maintainability; [ITER\\_D\\_RUGWUK](#)
- [49]. Safety of Machinery – Essential Health and Safety Requirement; [ITER\\_D\\_Q4NL36](#)
- [50]. Lifting Equipment and Operations – Important Safety Aspects; [ITER\\_D\\_SJNV4N](#)
- [51]. Template of CWP BOM; [ITER\\_D\\_UDCUXF](#)
- [52]. Release Note Template; [ITER\\_D\\_QVEKNQ](#)
- [53]. Package & Packing List Template; [ITER\\_D\\_XBZLNG](#)
- [54]. Delivery Report Template; [ITER\\_D\\_WZPYVZ](#)
- [55]. Nuclear Pressure Equipment Order of 30 December 2015 modified, Arrêté du 30 décembre 2015 relatif aux équipements sous pression nucléaires, modifié
- [56]. RCC-MR, Design and construction rules for mechanical components of nuclear installations, *Règles de Conception et de Construction des Matériels Mécaniques des Ilots Nucléaires RNR*, Edition 2007
- [57]. EN ISO 9712 of NDT personnel
- [58]. Tolerance drawing 026141\_VV Tolerance Requirements \_Part1 (rev. P) ; 2YGYBE
- [59]. Risk analysis for repair of VV assembly welds bevel by build-up ; [ITER\\_D\\_7TJAYY](#)
- [60]. Additional Requirements for the PQR and test coupons ; [ITER\\_D\\_9R6Z86](#)
- [61]. Attachment 1- VV S06/07 As Built Sector Edges Detailed Analysis - Outer Splice Plates [ITER\\_D\\_7NXP9C](#)
- [62]. Attachment 1- VV S07/08 As Built Sector Edges Detailed Analysis - Outer Splice Plates  
ITER\_D\_8BEBPU

## 5 Contract Execution

### 5.1 Outline of Contract Implementation

The contract execution can be divided into following main phases:

#### Phase 1: Repair Strategy Definition

This part of the contract consist in;

- a) Repair strategy description, including codes and standards, welding, NDT, machining, structural integrity, welding numerical simulation, regulatory relation
- b) Project development plan: schedule, cost, industrial treatment

To be concluded with Technical & Project review and IO approval

#### Phase 2: Readiness for Repair

This part of the contract consist in

- a) Welding development: validation note, mock-ups, PQR, welding book
- b) NDT development: NDT qualification program, test procedures, calibration samples
- c) Structural integrity: Structural Integrity Report update
- d) Machining development: mock-up test program and report
- e) Regulatory relation: analysis and production of required documents with ANB, issuing of NCR

To be concluded with Technical & Project review and IO approval. Acceptance by ANB of NCR

#### Phase 3: Repair S7

#### Phase 4: Repair S8 Side A

#### Phase 5: Repair S6

#### Phase 6: Repair S8 Side B

#### Phase 7: Acceptance and Final Dossier

### 5.2 Time Schedule

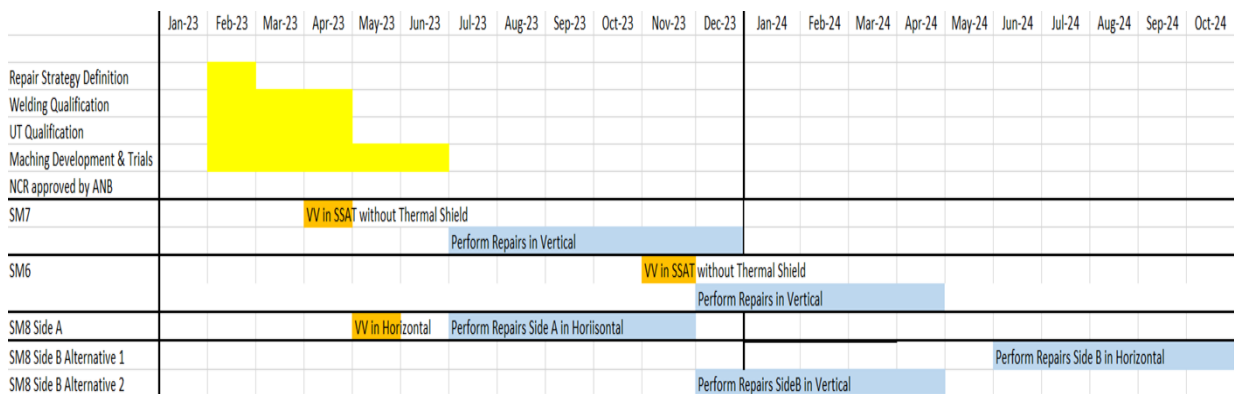
Proposed milestones of the contract execution are described in table 5.1.

IO has taken different assumptions for this schedule, including performing the repair with 2 teams, 2 shifts.

Nevertheless, the supplier shall produce their own schedule, with the premises of executing the repairs with high quality and minimizing overall duration. A detailed schedule showing all phases of the contract and it shall be submitted for the kick-off meeting.

**Table 5.1 – Main Milestones Contract Execution.**

Kick of meeting	T0
Phase 1: Repair Strategy Definition	T0 +1 months
Phase 2: Readiness for Repair	T0 + 5 months
Phase 3: Repair S7	T0 + 11 months
Phase 4: Repair S8 Side A	T0 + 11 months
Phase 5: Repair S6	T0 + 15 months
Phase 6: Repair S8 Side B	T0 + 21 months
Phase 7: Acceptance and Final Dossier	T0 + 22 months



## 6 Experience and Profile Requirements

The Contract will require competences and experiences in a number of key areas. This list is not exhaustive and only indicative of the anticipated skills.

**Table 6.1 – Main Milestones Contract Execution.**

Experience
Manufacturing of ESPN level 1 or 2 equipment, or Manufacturing of safety classified mechanical equipment for Nuclear Plants or installations
Relevant Codes and Standards
Welding: process qualification, welders training and qualification, tooling development
Structural integrity justification
Inspection and Non-Destructive Examination: UT, RT, PT
Precision Machining
Metrology: standard metrology, 3D scan
Quality Assurance / Quality Control
Clean Conditions Scaffolding
Cleaning

## 7 Work Description

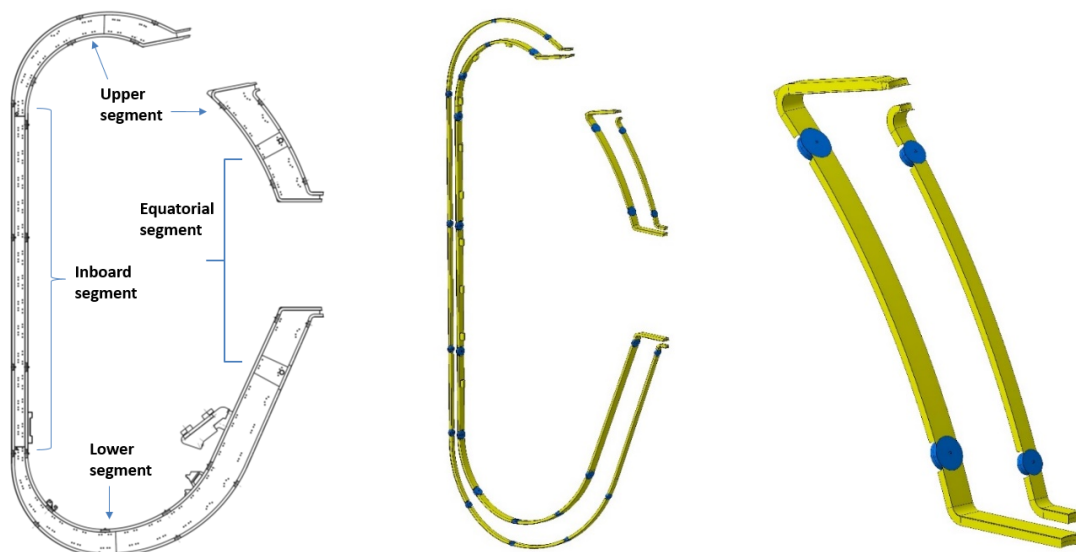
### 7.1 General description

#### 7.1.1 Introduction of Vacuum Vessel Field Joint

The VV is manufactured in the factory as nine double-wall sectors each spanning 40°. Each of the sectors will be assembled together with VV Thermal Shields panels and two Toroidal Field (TF) coils to form a Sector Module (SM). After the sector modules are installed in the pit, nine Field Joints (FJ) will be welded by using Splice Plates (SP) to compensate for the dimensional differences of the sectors and to complete 360° of the VV torus.

The gap and mismatch between the sectors will be measured and splice plates will be machined to fit prior to the welding. The baseline welding method is narrow gap automated TIG (tungsten inert gas).

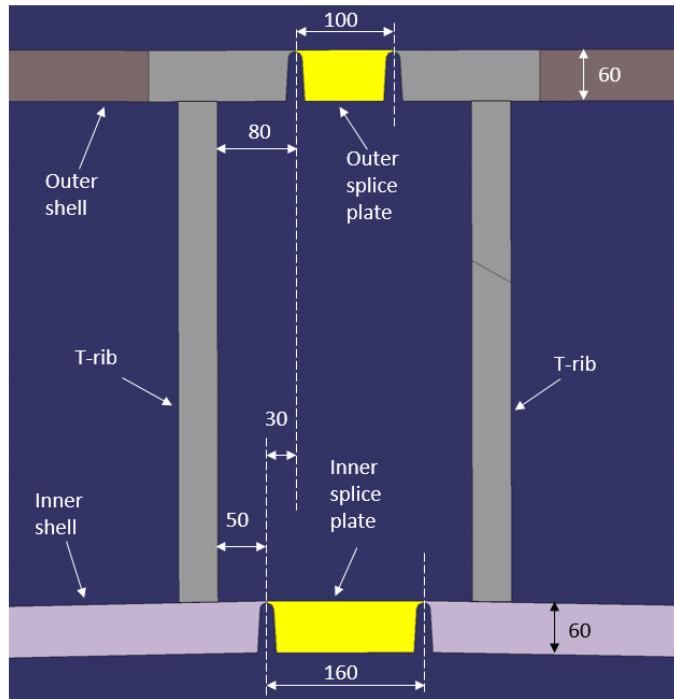
Given the nature of the welding and the complexity of the structure, it is needed to face the shrinkage and distortion of the components while welding. For these reasons, the splice plates are segmented into several segments and welded by a few of batches. Also several biscuits are located between segments as shown in Figure 7-1.



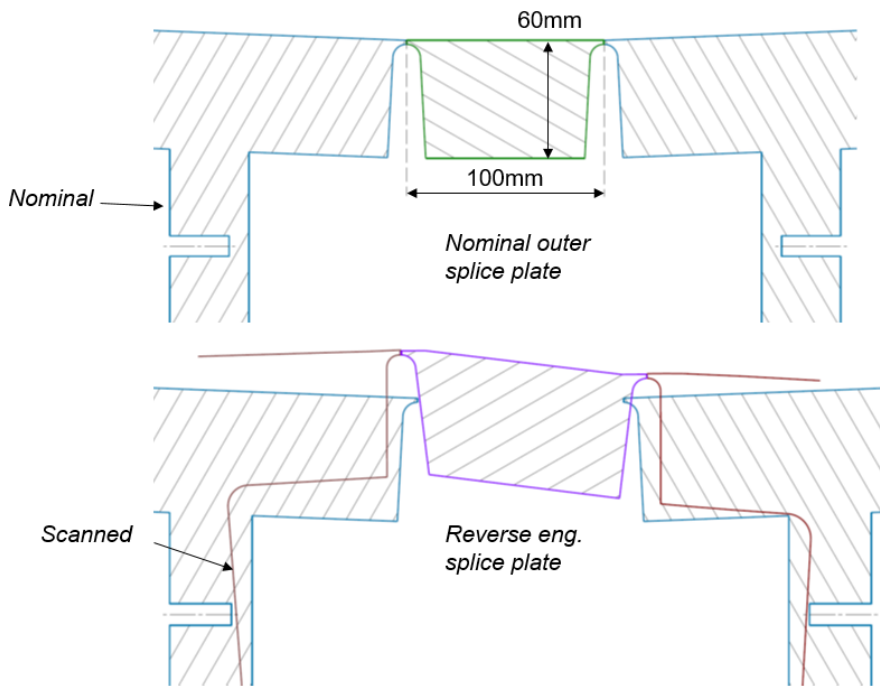
**Figure 7-1. VV Sector and Splice plates**

Figure 7-2 shows a representative cross-section of the field joint with the outer and inner splice plates in nominal configuration. Outer splice plate of 100 mm width is to be welded firstly with access from inner part with 160 mm of wider opening. One of important dimension in accessibility from inner side is 30 mm distance between inner and outer bevel edge. Also there is side rib located closely assembled during sector manufacturing. Figure 7-3 is an example of a reverse engineered configuration for an outer splice plate (upper figure: nominal, lower figure: actual) showing deviation between nominal and actual configuration.





**Figure 7-2. Representative cross-section**



**Figure 7-3. Nominal and actual configuration for other field joint with splice plate as example**

### 7.1.2 VV Dimensional Data for Analysis

In order to analyse dimensional deviation on field joint area, three dimensional scanning on related surface (sector bevel edge) is required. All dimensional data included in this specification come from scanned data. The sector edge surfaces from 3D scanning data is reconstructed with CAD data which is to be provided to contractor as part of document package (See Figure 7-4).

The reconstructed scanned surfaces have been compared to CAD nominal through the complete perimeter of the VV sector edges (S6 and S7). For each splice plate, several parameters have been measured (see Figure 7-5).

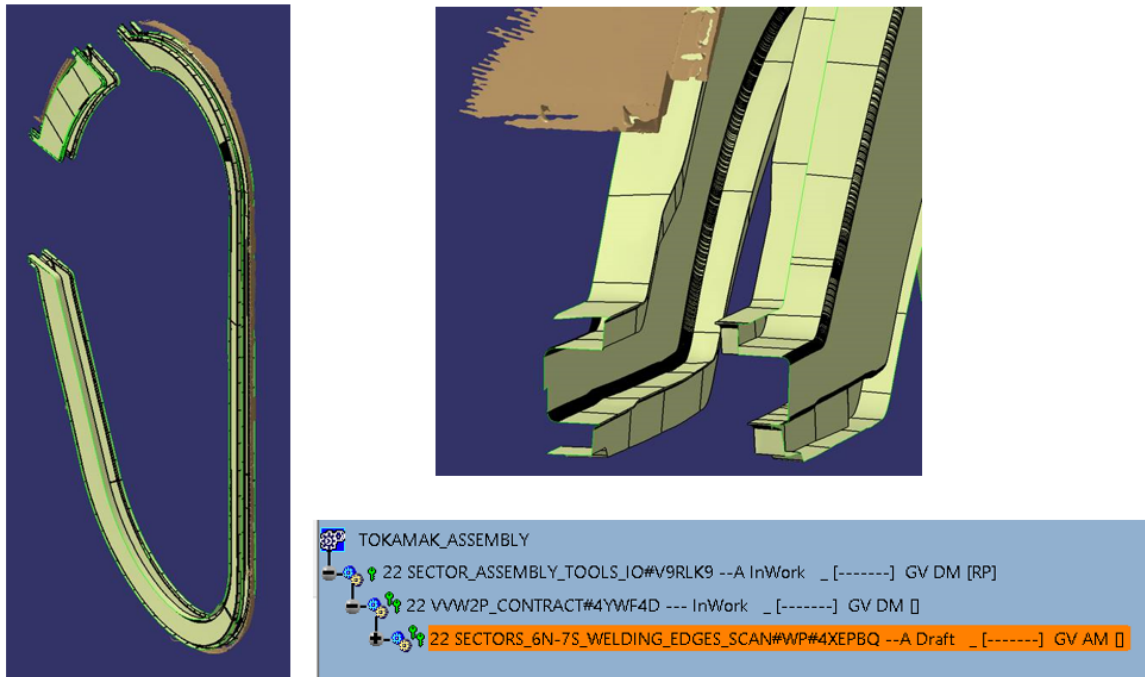


Figure 7-4. VV S6-S7 Reconstructed sector edge surfaces

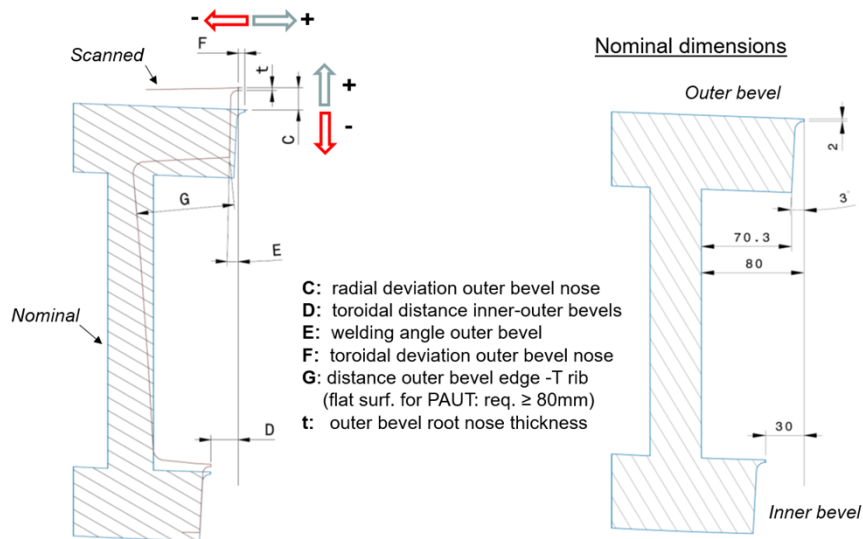
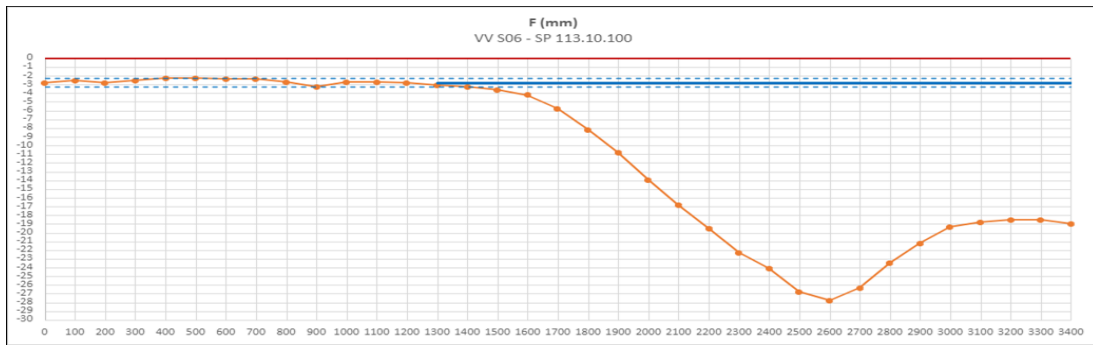


Figure 7-5. VV S6-S7 Sector edge bevels – Scanned data vs. CAD nominal

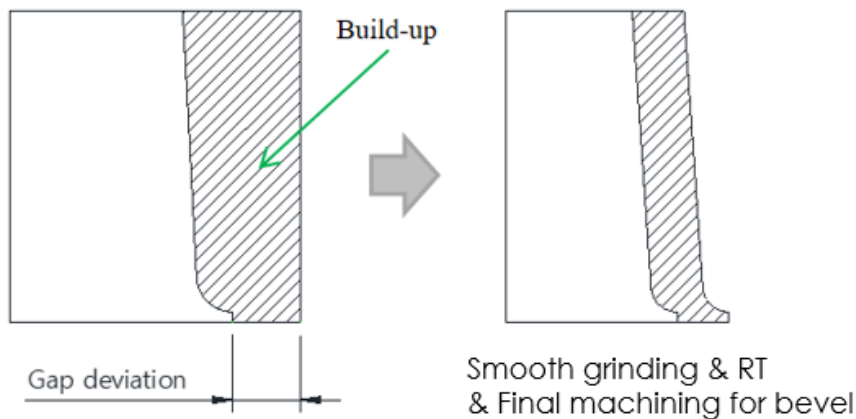
### 7.1.3 Repair type and scope

As defined in section 2, three kinds of repair types (Type 1~3) shall be considered. Each repair type is described in detail;

- 1) Toroidal deviation of outer bevel nose edge (F)
  - a. In order to increase the welding feasibility, the deviation (F) needs to be recovered to an acceptable value, defined by the blue line as shown in Figure 5-6. This is one representative configuration. This deviation will have variation for each splice plate region per sectors. See Table 7-1, 7-2, 7-3 for more information.
  - b. The proposed repair for the toroidal deviations cases will be build-up by welding, NDE and final machining, as described in the figure 7-7.



**Figure 7-6. Toroidal deviation to be repaired**



**Figure 7-7. Outer bevel repair – built-up**

- 2) Bevel nose thickness (t)
  - a. In order increase the welding feasibility, the root nose thickness needs to be homogenized within a splice plate to within a tolerance of + 0.2 mm.
  - b. The Figure 7-8 is an example of the thickness values for splice plate 40 of sector 6 with the proposed corrected homogeneous thickness in blue.
  - c. The proposed repair for these cases will be the following (see Figure 7-9)
    - i. Repair of bevel thickness (grinding only): in case of over-thickness
    - ii. Repair of bevel thickness (build up + grinding): in case of under-thickness



Figure 7-8. Outer bevel nose thickness S6

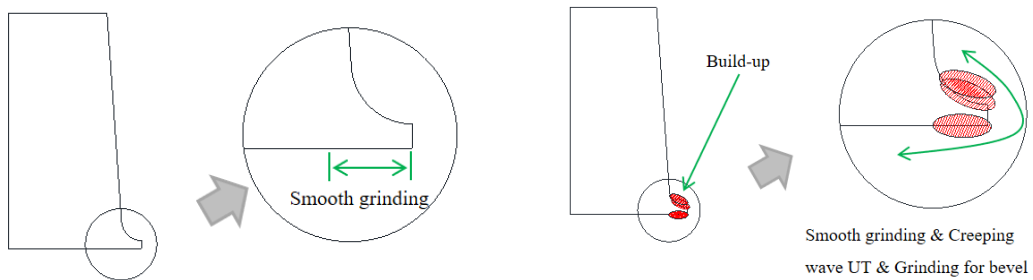


Figure 7-9. Root nose bevel repair – build-up & grinding

3) Welding Bevel Angle (E)

- a. In order to increase welding feasibility, it is proposed to recover the nominal 3 degrees in the outer bevel angle. The weld head needs to be tilted where the welding bevel angle of 3° is not respected, which induces collisions with the inner shell and additional welding risks.
- b. The proposed repair for these cases will be recovery to original requirement (bevel angle) by grinding or machining (See Figure 7-10)

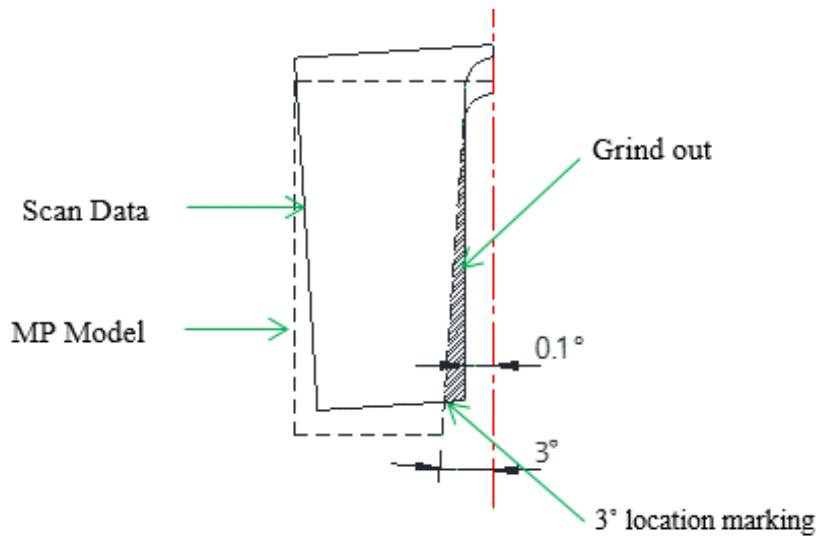


Figure 7-10. Outer bevel welding angle repair – grinding

The most dominant repair of them will be build-up by welding for recovering the dimensional deviation in toroidal direction. Table 7-1, 7-2, 7-3 show length to be repaired for each splices of three sectors, respectively. As noted in the bottom of each Table, as this information is only for one side (A or B), repair length on opposite side is considered as similar level in this specification.

**Table 7-1 Repair length/region for Repair type A of sector 6 one side**

Splice plate		Length to be recovered in poloidal direction (mm)			Remark
ID	Length (mm)	Length	Region (mm)	Max deviation (mm)	
SP 20	1400	-	-	-	
SP 30	2300	700	0 ~ 700	10	
SP 40	2500	600	1900~2500	12	
SP 50	2600	-	-	-	
SP 55	1600	300	0 ~ 300	9	
SP 60	1500	900	600 ~ 1500	13	
SP 70	1300	-	-	-	
SP 80	1500	-	-	-	
SP 90	1500	-	-	-	
SP 100	3400	1700	1700 ~ 3400	23	
SP 130	1800	1300	300 ~ 1500	12	
Total length	21400	5500			

Note) Opposite side to be considered as similar repair scope

**Table 7-2 Repair length/region for Repair type A of sector 7 one side**

Splice plate		Length to be recovered in poloidal direction (mm)			Remark
ID	Length (mm)	Length	Region (mm)	Max deviation (mm)	
SP 20	1400	-	-	-	
SP 30	2300	400	0 ~ 400/500	8.5	
SP 40	2500	600	1900~2500	8	
SP 50	2600	-	-	-	
SP 55	1600	800	0 ~ 800	3	
SP 60	1500	800	700 ~ 1500	8	
SP 70	1300	500	0 ~ 500	6	
SP 80	1500	1500	0 ~ 1500	12	
SP 90	1500	1500	0 ~ 1500	12	
SP 100	3400	1700	100~500 and 1600~3000	9	
SP 130	1800	1500	300 ~ 1800	24	
Total length	21400	8400			

Note) Opposite side to be considered as similar repair scope

**Table 7-3 Repair length/region for Repair type A of sector 8 one side**

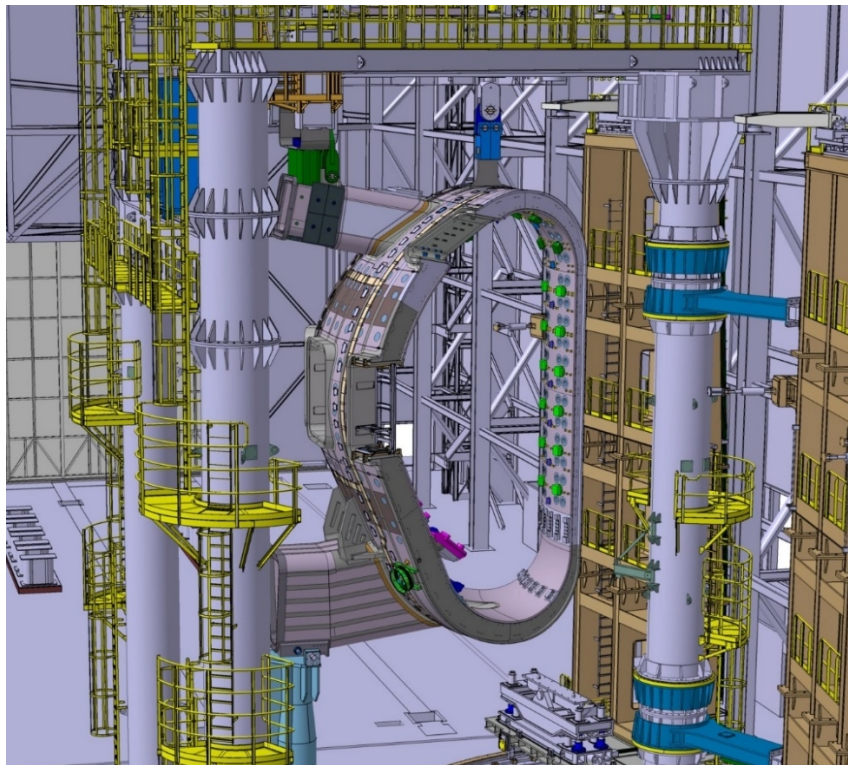
Splice plate		Length to be recovered in poloidal direction (mm)			Remark
ID	Length (mm)	Length	Region (mm)	Max deviation (mm)	
SP 20	1400	600	800 ~ 1400	10	
SP 30	2300	2300	0 ~ 2300	20	
SP 40	2500	1000	1500~2500	12	
SP 50	2600	-	-	-	
SP 55	1600	400	0 ~ 400	9	
SP 60	1500	1500	0 ~ 1500	20	
SP 70	1300	1300	0 ~ 1300	26	
SP 80	1500	1500	0 ~ 1500	28	
SP 90	1500	1500	0 ~ 1500	27	
SP 100	3400	3000	0 ~ 3000	39	
SP 130	1800	1400	200 ~ 1600	12	
Total length	21400	14500			

Note) Opposite side to be considered as similar repair scope

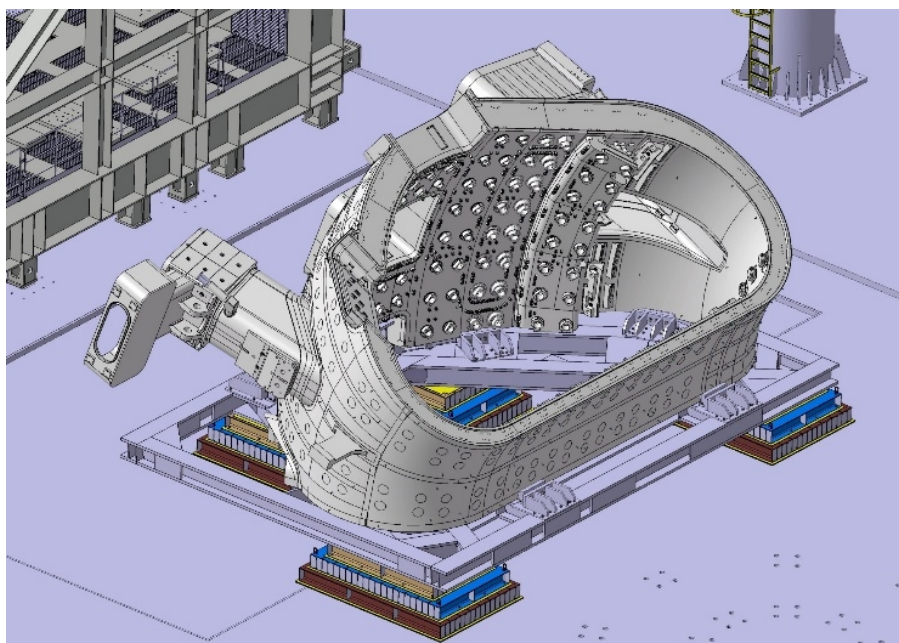
## 7.2 General requirement

### 7.2.1 Repair configuration

The repair shall be performed in vertical configuration on SSAT for Sector 6 and Sector 7 and in horizontal configuration for Sector 8. Figure 7-11 and Figure 7-12 show both repair configuration as above mentioned, respectively.



**Figure 7-11. Repair configuration (in vertical) for sector 6 and sector 7 (only for information)**



**Figure 7-12. Repair configuration (in horizontal) for sector 8 (actual interface tool different)**

Two possible scenarios are foreseen to repair the opposite side of Sector 8.

Either

- a) the sector is turned around, and the opposite side is thus accessible and repaired in horizontal
- b) or it is lifted vertically and the opposite side is repaired in vertical

All the handling operations to prepare the sectors for repair operations will be performed by other IO contractors and is out of the scope of this specification.

### 7.2.2 *General repair sequence*

The Figure 7-13 shows the flow with repair sequence. The detail requirement for following key operation is described in section 7.3 to 7.9

- 1) Access
- 2) Protection for cleanliness
- 3) Build up welding
- 4) Machining
- 5) NDE
- 6) Dimensional inspection

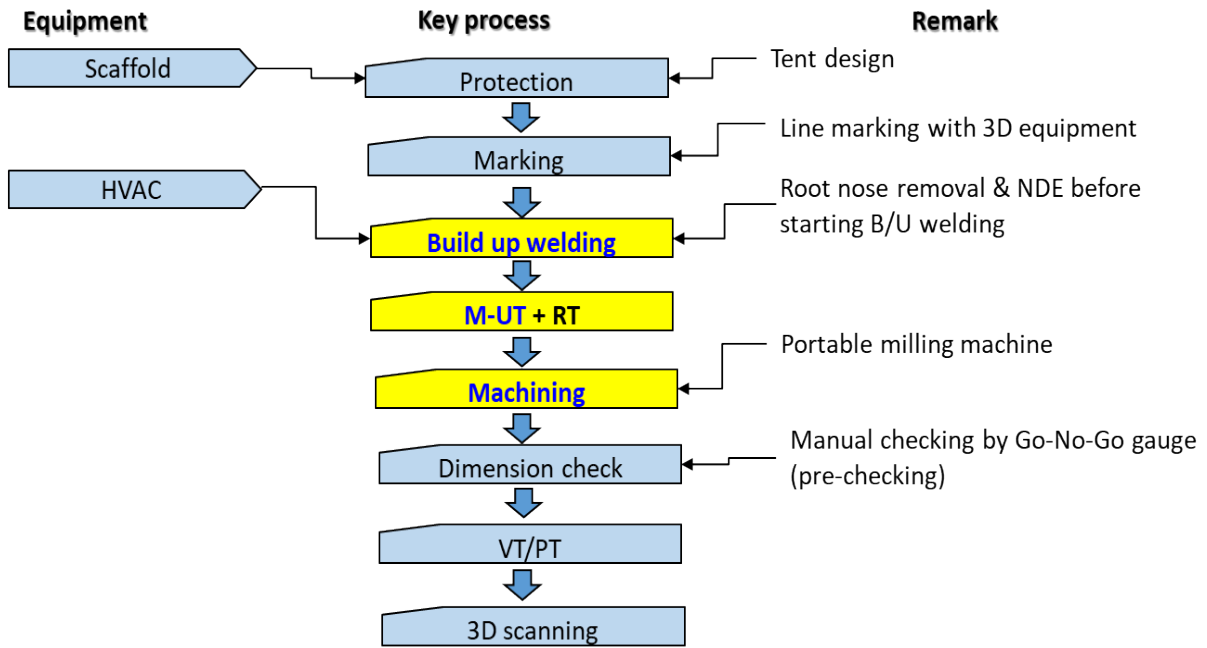
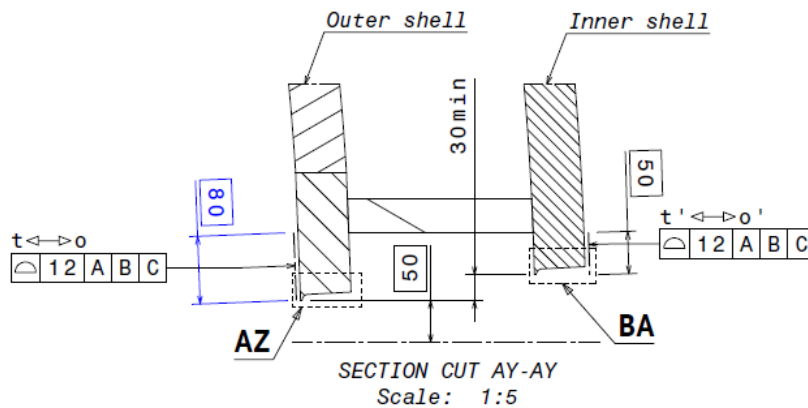


Figure 7-13. Flow chart for key repair sequencer

7.2.3 Tolerance requirement

Sector tolerance drawing shall be considered as general requirement if there is no conflict to specific requirement [58]. The following tolerance shall be prioritized. Figure 7-14 shows tolerances of site bevel.

- Bevel root nose thickness: 0 ~ +0.2 mm





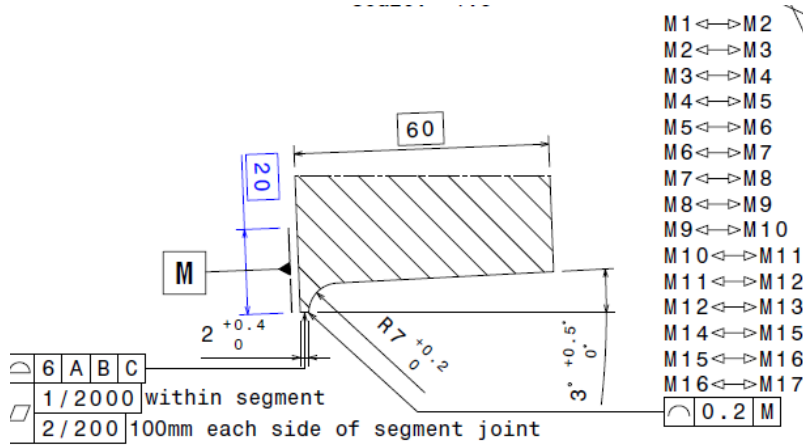


Figure 7-14. Site bevel tolerances

### 7.3 Scaffold for access

The contractor is responsible for providing accessibility for all repair operation. Figure 7-15 shows one example of sector on SSAT with installed scaffold. In particular, similar scaffold located at side A, B shall be considered.

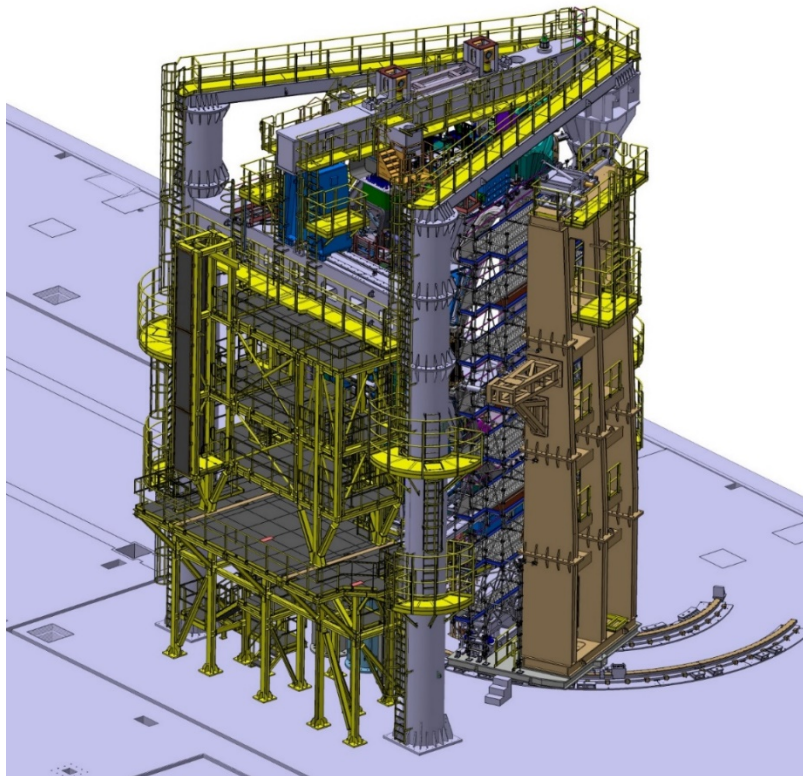


Figure 7-15. Example of sector on SSAT with installed scaffold

## 7.4 Protection for cleanliness

The contractor shall propose protection and preservation plan for cleanliness.

## 7.5 Build-up welding

### 7.5.1 *Material and Welded Assembly Design Rules*

The ITER Vacuum Vessel sector is manufactured from stainless steel 316L (N)-IG according to Section 2 RM 3321 and RM 3331. The VV is an RCC-MR class 2 box structure and RC 3833 design rules apply for the welded joints. The same design rule for welded assembly shall be applied for repair.

### 7.5.2 *Welding Processes*

Repair welding shall be performed according to RS 7350. The contractor shall propose and select repair welding processes. It is recommended to use manual or automatic TIG weld. Other proposals of supplier can be considered.

Initiation and stopping points of all welded passes and weld layers have to be staggered.

The stops and starts shall be dressed/wire brushed to remove oxide films/residual flux.

### 7.5.3 *Welding Procedure Qualification (if applicable)*

All welding procedures qualifications shall conform to RS 3000. The hot tensile test following RS 3234 shall be carried out at 200°C. Strength requirements are taken from filler material data sheets and are at least equal to the base material.

The qualification welding procedure shall be approved by NB or RTPO (according to A18.3253.1) for joints that contribute to pressure resistance and the parts attached to them. Adequacy and validity will be checked by IO and the ANB before start of repair.

### 7.5.4 *Filler material*

#### Qualification of Filler Material

This deals with the qualification test performed on filler material for which a trade designation qualification is required and conforms to RS 5000. This qualification is not required for protective gas, bare rods, wires or consumable inserts. The qualification of filler material shall be done under the supervision of the contractor.

#### Acceptance of Filler Material

Filler material shall be procured according to RS 2000. Adjustment of the chemical composition on maximum Cobalt content may be needed and shall be agreed with IO. A hot tensile test shall be carried out at 200°C. Strength requirements are given in filler materials data sheets.

The contractor shall ensure that they are conducted in the presence of the Quality Control Department of the filler material provider. Filler material selection shall be submitted to IO's approval. Low ferrite content (in the range of 3 to 10%) is recommended.

In case of use of filler material not referenced in RCC-MR data sheets (RS 2700 and RS 2900), the contractor shall submit to IO for approval; a specification data sheet mentioning the results to be obtained. The qualification reports of filler material shall be submitted to IO.

It is recommended to use TIG filler material ER316L according to RCC-MR RS 2915 for consistency with the field joint weld. Other proposals of supplier can be considered.

#### Storage and Use of Welding Materials

A process of electrode/wire return to stores shall be set up to ensure full traceability of material. Storage conditions and use of the welding materials shall be in accordance with RS 7200 and shall demonstrate the adequacy of material reception, storage, stock control, drying and conservation.

##### *7.5.5 Welder qualification*

Qualification tests for welders and operators shall be carried out in accordance with the full requirements of RS 4000.

The qualification and technical skill of the welders is established under the Contractor's responsibility and approved by ASN agreed RTPO for joints that contribute to pressure resistance and parts attached to them. Adequacy and validity will be checked by IO and the ANB before start of production welds.

##### *7.5.6 Repair welding execution*

Qualification tests for welders and operators shall be carried out in accordance with the full requirements of RS 4000.

The preparation and examination of edges and surfaces for welding shall conform to RS 7300.

Weld surface finishing shall be compatible with the performance of non-destructive examination and vacuum requirements.

In case of manual TIG weld, risk mitigation measure according to IO risk analysis shall be taken by the contractor.

##### *7.5.7 Visual and dimensional examination*

RS 7460 prescribes acceptance criteria and methods are covered by RMC 7100.

Visual and dimensional control shall be carried out before the execution of other required non-destructive examinations.

Dimensional examination methods shall be specified by the Contractor.

## **7.6 Machining**

A portable milling machining shall be used for re-machining the bevel after build-up. The equipment shall be verified for its function and performance through test trials before the implementation of the repair. In case that an equipment frame (or rail) needs to be fixed onto the VV surface or existing thread holes, the related procedure and justification shall be accepted by IO/ANB.

## 7.7 Non-Destructive Examination

The NDE of class 2 component production welds are provided in RS 7720.

### 7.7.1 *Surface examination*

According to A19.4200, surface examination can be done by liquid penetrant.

### 7.7.2 *Volumetric examination*

Concerning volumetric examination of welds, the reference method shall be radiographic examination. As supplementary inspection, UT shall be performed.

In case jig/fixture is used for welding, welds between jigs and the VV shall be inspected by visual, surface and volumetric examination.

### 7.7.3 *NDE for execution weld*

NDE requirements before, during and after welding are gathered in RS 7720 and its tables RS 7720c1, c2 and c3 for class 2 box structures.

For ultrasonic examination the, RS 7724.41 criteria are to be applied.

All welds failing examination are to be repaired using qualified procedures and then examined again with the same requirements. All weld tests and retests are to be recorded

### 7.7.4 *NDE method*

- 1) Visual examination
  - a. Visual examination equipment shall be verified in accordance with RMC 7100.
- 2) Liquid penetration examination
  - a. Liquid penetrant examination method shall comply with the requirements of RMC 4000.
  - b. Reference blocks used for the performance test are supplied along with the ITER VV.
  - c. Penetrants and developers used for VV vacuum surfaces testing comply with the following requirements:
    - i. short evaporation times (in order to minimize outgassing rate).
    - ii. low sulphur and halogen (chloride + fluoride) contents (according to RF 6423, the maximum halogen and sulphur content of penetrants and developers for examination of austenitic stainless steel surfaces is 200 ppm).
  - d. A campaign test in order to validate the liquid dye penetrant according to vacuum requirements will be done by the IO.
- 3) Radiographic examination
  - a. Radiographic examination equipment complies with all requirements listed in RMC 3000 and in particular RMC 3300 related to radiographic examination of welds.

- 4) Ultrasonic examination
  - a. Prior to the build-up UT examination a procedure shall be submitted and subject to a demonstration on a representative build-up coupon. This demonstration shall be approved by the IO and the ANB. The UT scanning shall be appropriate to detect inter-layer (and possibly inter-pass) defects.
- 5) Leak testing examination (if applicable)
  - a. Dedicated procedure shall be approved by IO/ANB

#### 7.7.5 *NDE Operators and Inspectors Qualification*

Qualification and certification of personnel responsible for performance or assessment of non-destructive examination results follow all requirements described in RMC 8000 including the certification system, definitions, required qualifications and certification provisions. Following A18.3253.1, NDE personnel shall be approved by ASN agreed RTPO under the Contractor responsibility. The document shall be available to IO and ANB for verification.

The following rules apply:

- 1) only personnel qualified and certified in accordance with EN ISO 9712:2012 perform NDE
- 2) only personnel qualified and certified level 3 in accordance with EN ISO 9712:2012 approve NDE procedures
- 3) for assemblies submitted to partial examination, IO can impose the selection of areas to be inspected

## 7.8 **Dimensional inspection**

The contractor is responsible for providing all tool/equipment for both manual and 3-dimensional inspection

## 8 **Responsibilities**

The technical responsibilities are distributed as following:

- ITER Organization, IO:
  - o IO shall provide the needed information and access to the appropriate ITER files for executing this work when needed. In particular, IO will make available any required technical information;
- Contractor:
  - o The Contractor shall appoint a responsible person who shall represent the Contractor for all matters related to the implementation of this contract;
  - o The task shall be performed according to the work outlined above;
  - o The Contractor shall provide the needed equipment for properly execute the task respecting the requirements;
  - o The Contractor shall report the results of the tests to IO providing a description of the used equipment and followed measurement methodology;
  - o The Contractor shall ensure the role of Manufacturer in the framework of the CE marking process.

## 9 List of deliverables and due dates

T0 = Contract signature date

Deliverable Ref.	Deliverable Description	Due Date
D1	Mobilization: - Quality Plan - Documents for on-site work permit - Implementation plan - Detail schedule - KOM	T0+4 weeks
D2	Documentation before implementation - ITP - Repair procedures	T0+6 weeks
D3	Repair implementation S7 (50% progress)	T0+TBD
D4	Repair implementation S7 (100% progress)	T0+TBD
D5	Acceptance and final dossier S7 - Filled ITP - Final acceptance report - Release note - Delivery report	T0+TBD
D6	Repair implementation S8 (50% progress)	TO-TBD
D7	Repair implementation S8 (100% progress)	TO-TBD
D8	Acceptance and final dossier S8 - Filled ITP - Final acceptance report - Release note Delivery report	TO=TBD
D9	Repair implementation S6 (50% progress)	TO-TBD
D10	Repair implementation S8 (100% progress)	TO-TBD
D11	Acceptance and final dossier S8 - Filled ITP - Final acceptance report - Release note Delivery report	TO-TBD

## 10 Acceptance Criteria

The following list shall be taken in to account by the Contractor:

- The deliverables shall be supplied to the ITER site.
- All related documentation, including engineering file, manufacturing data, certification, test data shall be delivered and accepted.

## 11 Specific requirements and conditions

Described in previous section

## 12 Work Monitoring / Meeting Schedule

The following progress meeting will be foreseen:

Scope of meeting	Point of Check/deliverable	Occurrence	Remark
Kick-off Contract Meeting	Implementation plan and detail schedule	1 meeting	
Weekly Progress Meeting	Weekly progress	Weekly	
Monthly Progress Meeting (report to be issued)	Monthly progress	Monthly	Report

## 13 Delivery time breakdown

The payment will be done by deliverables invoicing justified by delivery of reports and the tools as described at Section 9.

## 14 Quality Assurance (QA) requirements

The organisation conducting these activities should have an ITER approved QA Program or an ISO 9001 accredited quality system.

The general requirements are detailed in [ITER Procurement Quality Requirements \(ITER\\_D\\_22MFG4\)](#).

Prior to commencement of the task, a Quality Plan must be submitted for IO approval giving evidence of the above and describing the organisation for this task; the skill of workers involved in the study; any anticipated sub-contractors; and giving details of who will be the independent checker of the activities (see [Procurement Requirements for Producing a Quality Plan \(ITER\\_D\\_22MFMW\)](#)).

Documentation developed as the result of this task shall be retained by the performer of the task or the DA organization for a minimum of 5 years and then may be discarded at the direction of the IO. The use of computer software to perform a safety basis task activity such as analysis and/or modelling, etc. shall be reviewed and approved by the IO prior to its use, in accordance with [Quality Assurance for ITER Safety Codes \(ITER\\_D\\_258LKL\)](#).

## 15 CAD Design Requirements (if applicable)

For the contracts where CAD design tasks are involved, the following shall apply:

The Supplier shall provide a Design Plan to be approved by the IO. Such plan shall identify all design activities and design deliverables to be provided by the Contractor as part of the contract.

The Supplier shall ensure that all designs, CAD data and drawings delivered to IO comply with the Procedure for the Usage of the ITER CAD Manual ([2F6FTX](#)), and with the Procedure for the Management of CAD Work & CAD Data (Models and Drawings [2DWU2M](#)).

The reference scheme is for the Supplier to work in a fully synchronous manner on the ITER CAD platform (see detailed information about synchronous collaboration in the ITER [GNJX6A](#) - Specification for CAD data production in ITER Contracts.). This implies the usage of the CAD software versions as indicated in CAD Manual 07 - CAD Fact Sheet ([249WUL](#)) and the connection to one of the ITER project CAD data-bases. Any deviation against this requirement shall be defined in a Design Collaboration Implementation Form (DCIF) prepared and approved by DO and included in the call-for-tender package. Any cost or labour resulting from a deviation or non-conformance of the Supplier with regards to the CAD collaboration requirement shall be incurred by the Supplier.

## 16 Safety requirements

ITER is a Nuclear Facility identified in France by the number-INB-174 (“Installation Nucléaire de Base”).

For Protection Important Components and in particular Safety Important Class components (SIC), the French Nuclear Regulation must be observed, in application of the Article 14 of the ITER Agreement.

In such case the Suppliers and Subcontractors must be informed that:

- The Order 7th February 2012 applies to all the components important for the protection (PIC) and the activities important for the protection (PIA).
- The compliance with the INB-order must be demonstrated in the chain of external contractors.
- In application of article II.2.5.4 of the Order 7th February 2012, contracted activities for supervision purposes are also subject to a supervision done by the Nuclear Operator.

For the Protection Important Components, structures and systems of the nuclear facility, and Protection Important Activities the contractor shall ensure that a specific management system is implemented for his own activities and for the activities done by any Supplier and Subcontractor following the requirements of the Order 7th February 2012.



## Annex A Detail information on dimensional deviations

This annex describes toroidal dimensional deviation of each of the three sectors available at IO.

- a) A description of one side for S6 is available. Assume that the other side is the same or equivalent.
- b) A description of one side for S7 is available. Assume that the other side is the same or equivalent.
- c) A description of both sides of S8 is available.

### A-1 Sector 6 facing sector 7

Figure A-1 show overall results on toroidal and bevel angle deviation for all splice plates

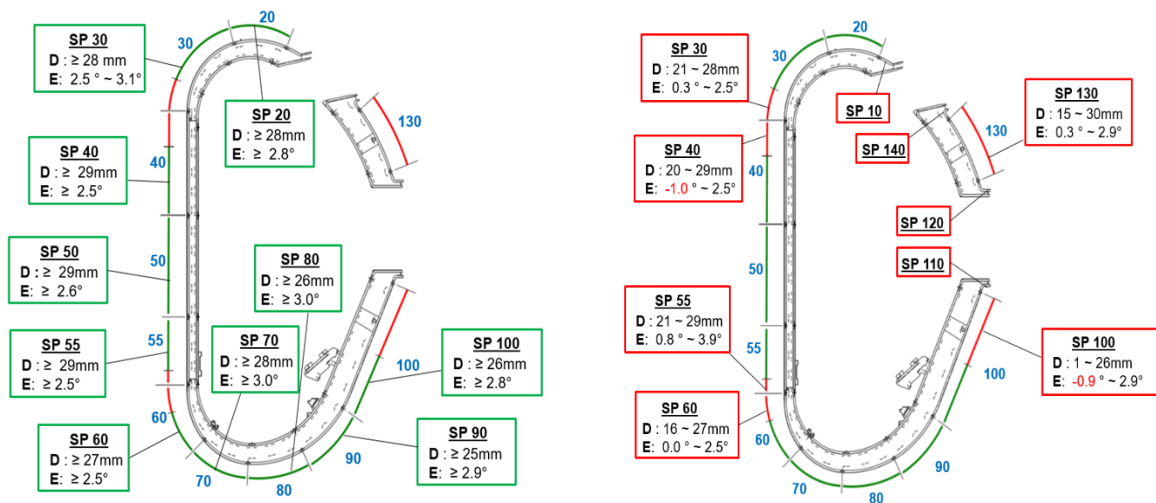
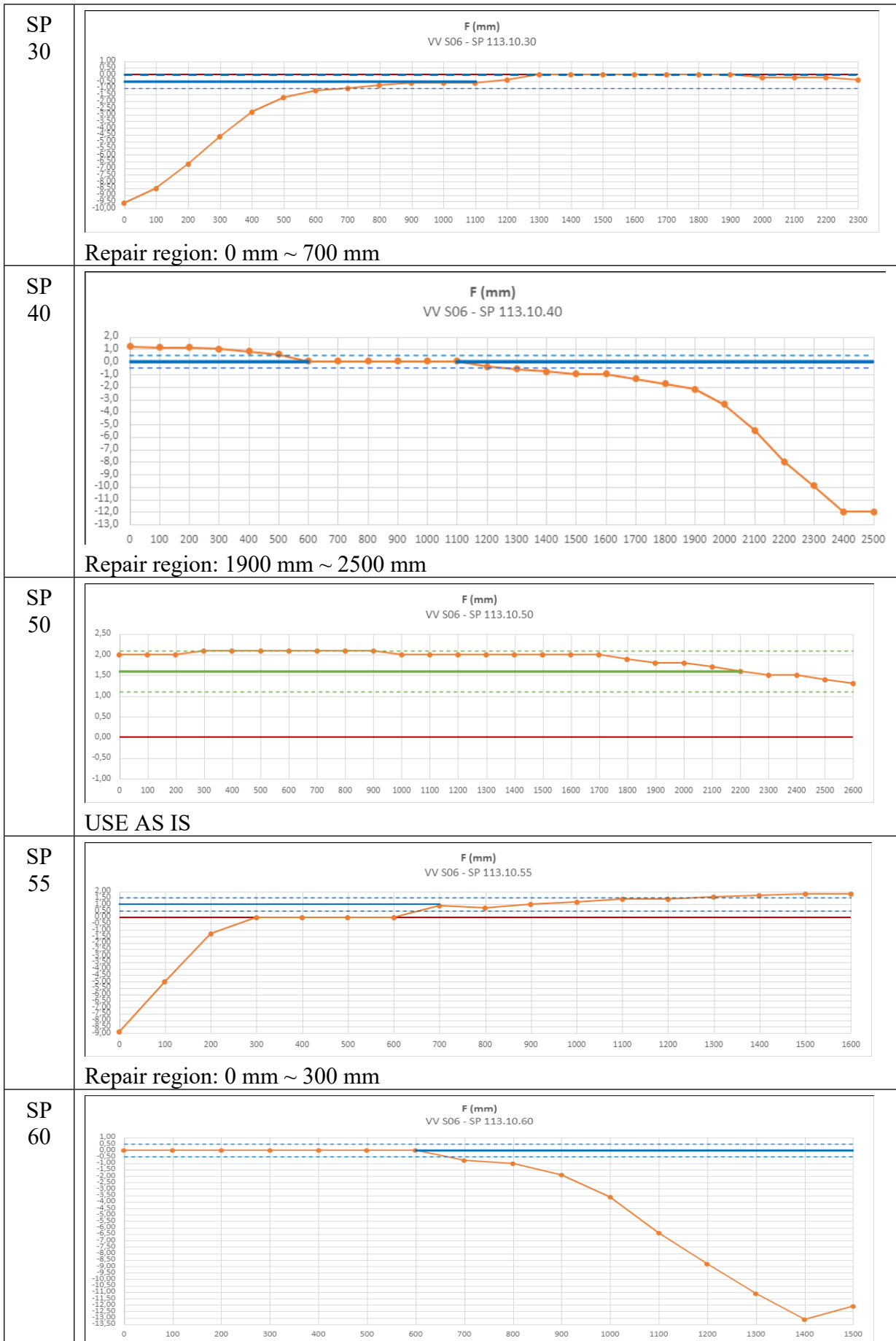


Figure A-1 Overall summary on toroidal and bevel angle deviation

Table A-1.1 Toroidal deviation and repair region on each splice plates

Splice plate ID	Toroidal deviation profile
SP 20	<p style="text-align: center;">F (mm) VV S06 - SP 113.10.20</p> <p style="text-align: center;">USE AS IS</p>



<p>SP 70</p>	<p>Repair region: 600 mm ~ 1500 mm</p> <p>F (mm) VV S06 - SP 113.10.70</p> <p>USE AS IS</p>
<p>SP 80</p>	<p>F (mm) VV S06 - SP 113.10.80</p> <p>No build-up – repair by machining</p>
<p>SP 90</p>	<p>F (mm) VV S06 - SP 113.10.90</p> <p>USE AS IS</p>
<p>SP 100</p>	<p>F (mm) VV S06 - SP 113.10.100</p> <p>Repair region: 1700 mm ~ 3400 mm</p>
<p>SP 130</p>	<p>F (mm) VV S06 - SP 113.10.130</p>

Table A-1.2 Bevel toe thickness deviation and repair region on each splice plates

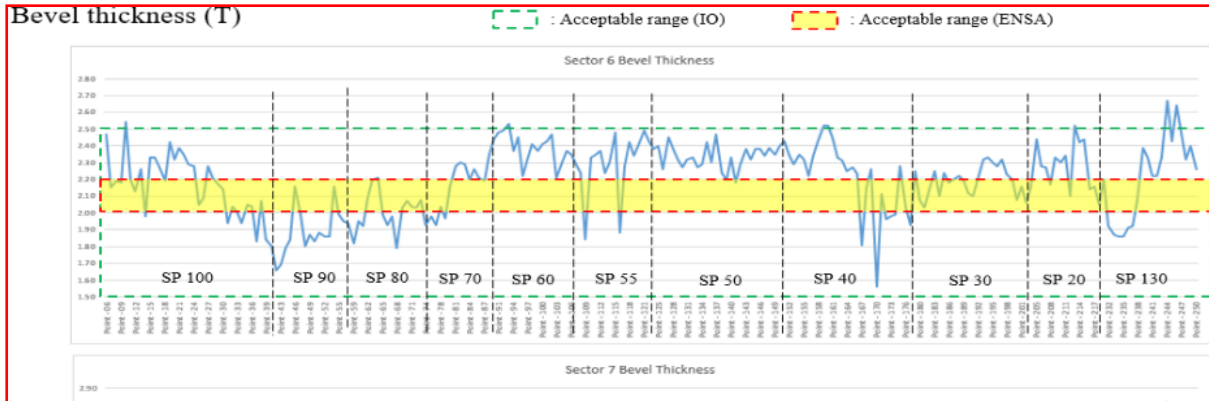
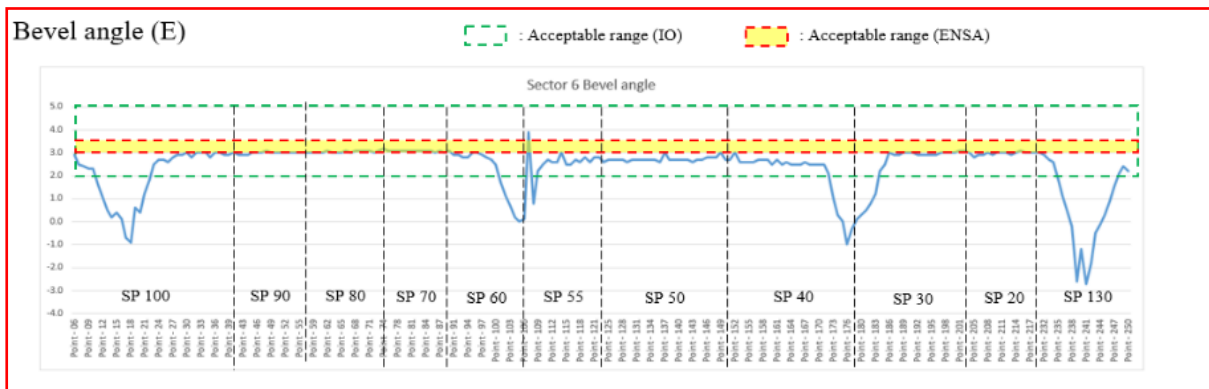


Table A-1.3 Bevel angle deviation and repair region on each splice plate



### A-2 Sector 7 facing sector 6

Figure A-2 show overall results on toroidal and bevel angle deviation for all splice plates

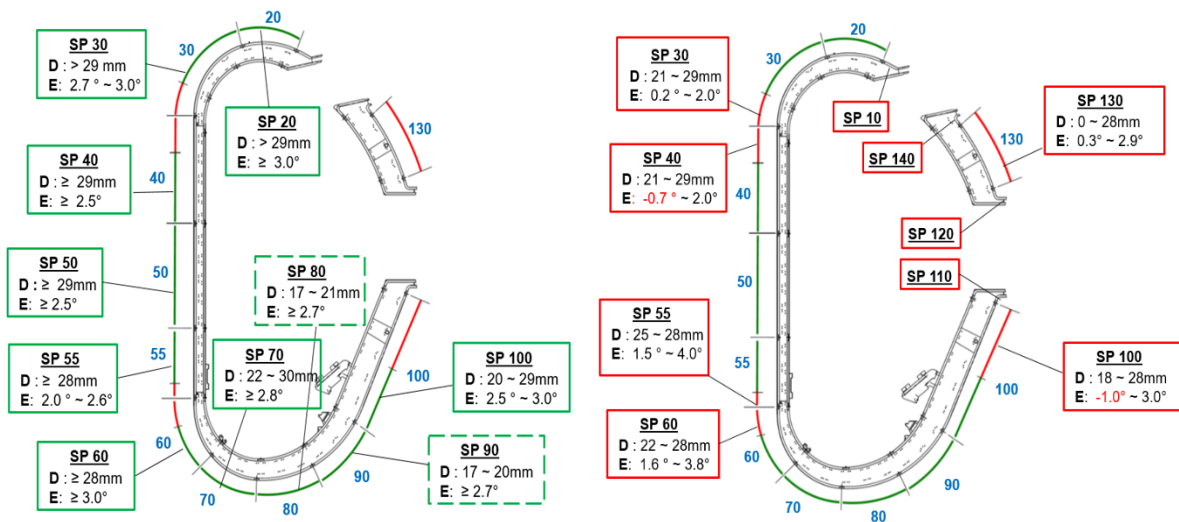
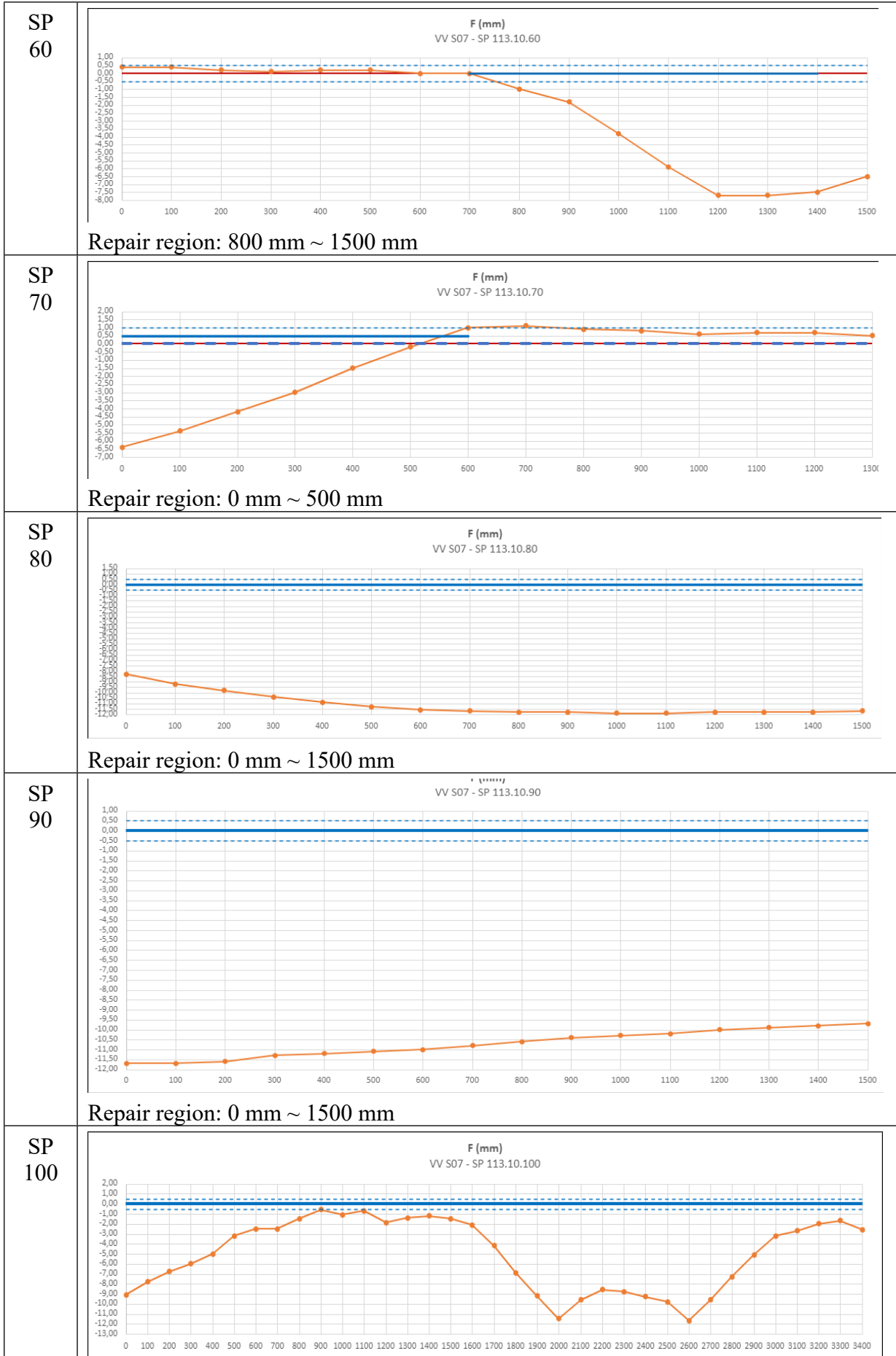


Figure A-2 Overall summary on toroidal and bevel angle deviation

Table A-2 .1 Toroidal deviation and repair region on each splice plates

Splice plate ID	Toroidal deviation profile
SP 20	<p>USE AS IS</p>
SP 30	<p>Repair region: 0 mm ~ 700 mm</p>
SP 40	<p>Repair region: 1900 mm ~ 2500 mm</p>
SP 50	<p>No build-up – repair by machining</p>
SP 55	<p>Repair region: 0 mm ~ 300 mm</p>



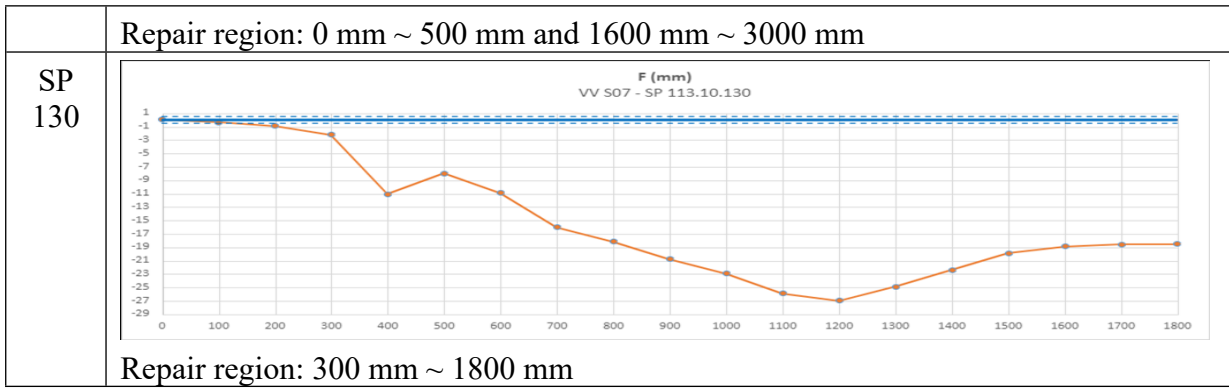


Table A-2.2 Bevel toe thickness deviation and repair region on each splice plates

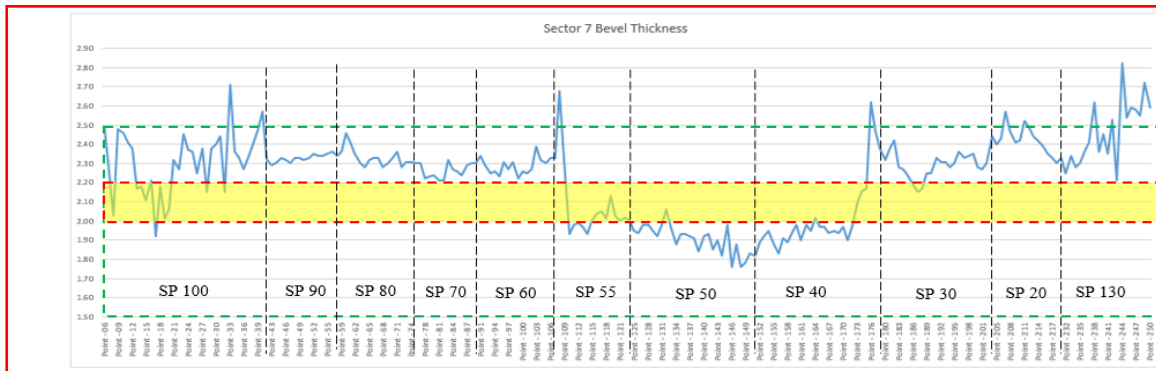
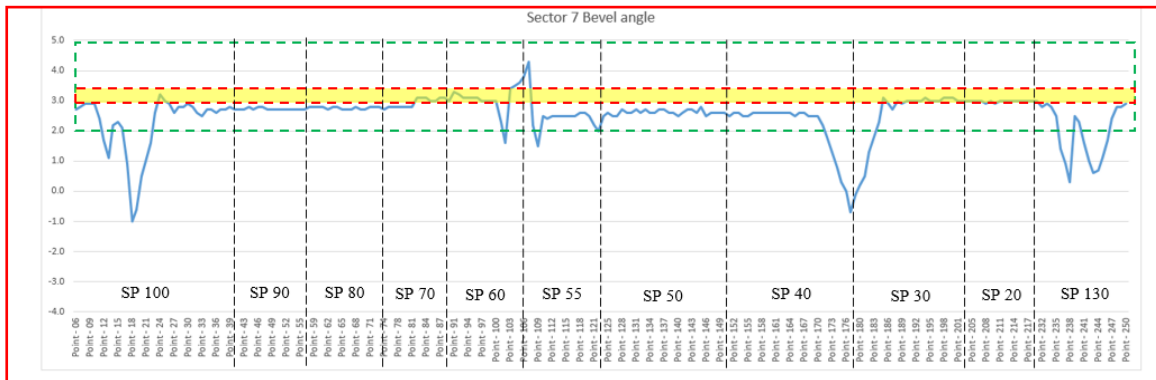


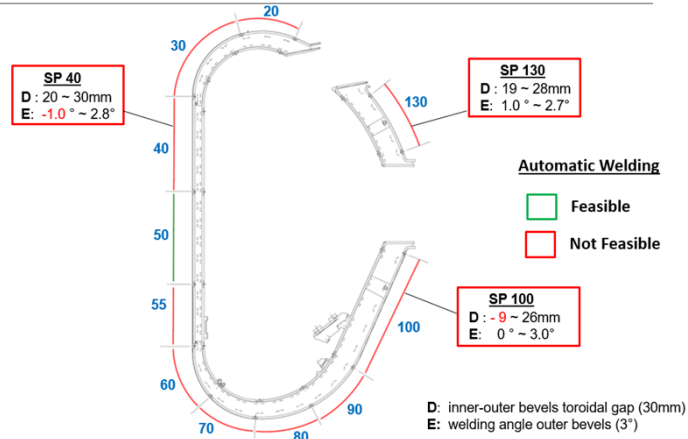
Table A-2.3 Bevel angle deviation and repair region on each splice plate



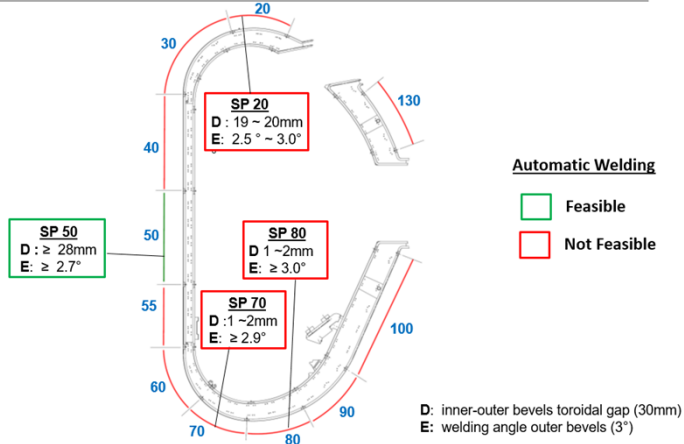
### A-3 Sector 8 facing sector 7

Figure A-3 show overall results on toroidal and bevel angle deviation for all splice plates

VV S08 – facing S07 (1<sup>st</sup> Batch)



VV S08 – facing S07 (2<sup>nd</sup> Batch)



VV S08 – facing S07 (3<sup>rd</sup> Batch)

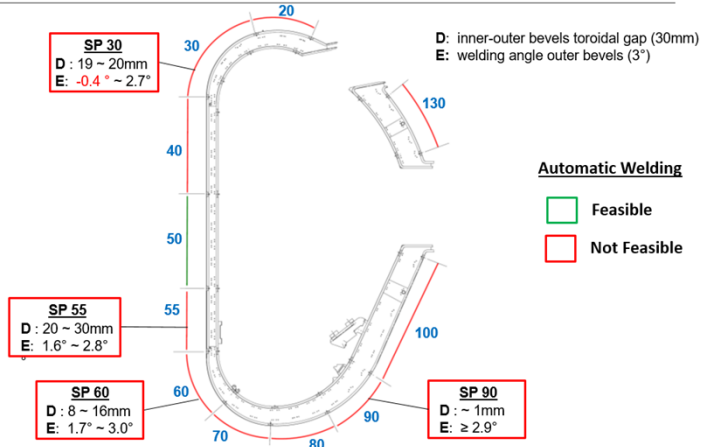
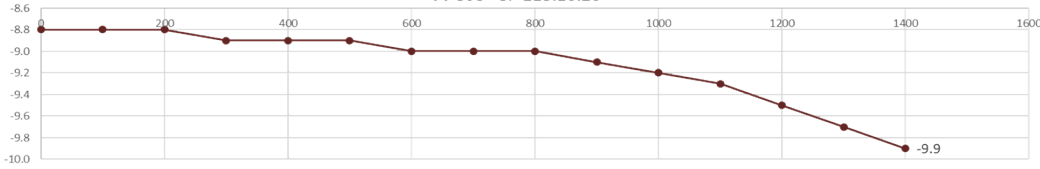
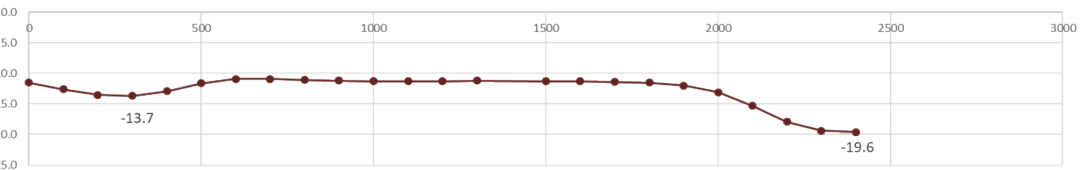
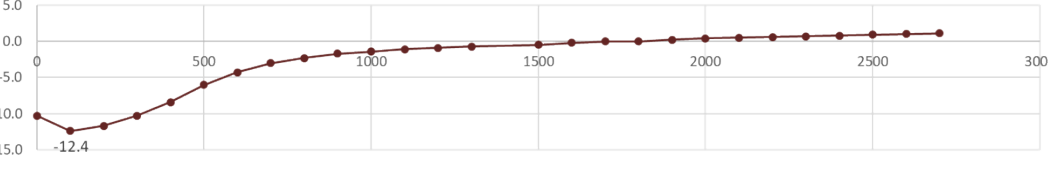
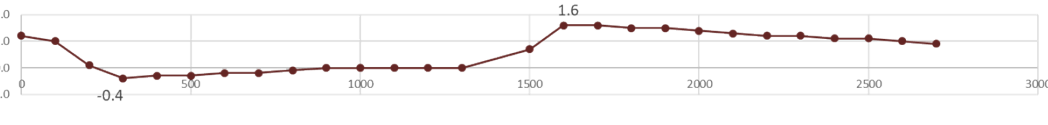
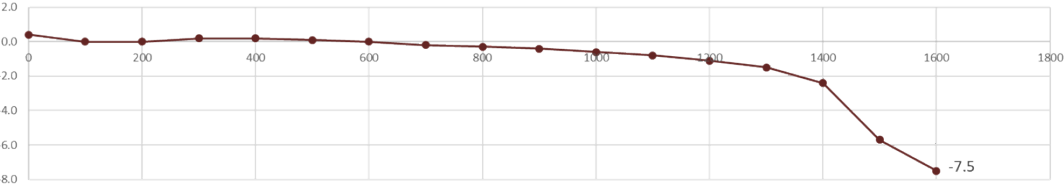
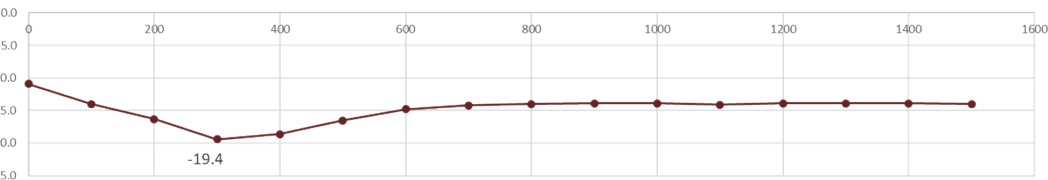


Figure A-3 Overall summary on toroidal and bevel angle deviation



Table A-3 Toroidal deviation only

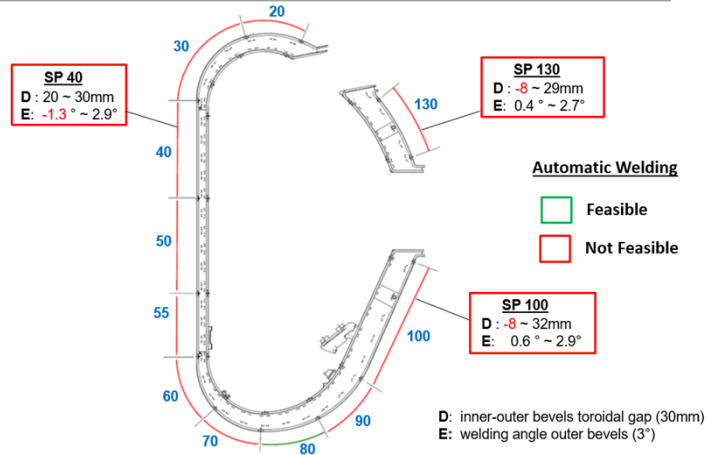
Splice plate ID	Toroidal deviation profile
SP 20	<p style="text-align: center;">F (mm) VV S08 - SP 113.10.20</p>  <p style="text-align: right;">-9.9</p> <p>Repair</p>
SP 30	<p style="text-align: center;">F (mm) VV S08 - SP 113.10.30</p>  <p style="text-align: center;">-13.7</p> <p style="text-align: right;">-19.6</p> <p>Repair</p>
SP 40	<p style="text-align: center;">F (mm) VV S08 - SP 113.10.40</p>  <p style="text-align: center;">500</p> <p style="text-align: center;">1000</p> <p style="text-align: left;">-12.4</p> <p>Repair</p>
SP 50	<p style="text-align: center;">F (mm) VV S08 - SP 113.10.50</p>  <p style="text-align: center;">500</p> <p style="text-align: center;">1000</p> <p style="text-align: center;">1500</p> <p style="text-align: center;">2000</p> <p style="text-align: center;">2500</p> <p style="text-align: center;">3000</p> <p style="text-align: left;">-0.4</p> <p style="text-align: right;">1.6</p> <p>USE AS IS</p>
SP 55	<p style="text-align: center;">F (mm) VV S08 - SP 113.10.55</p>  <p style="text-align: center;">200</p> <p style="text-align: center;">400</p> <p style="text-align: center;">600</p> <p style="text-align: center;">800</p> <p style="text-align: center;">1000</p> <p style="text-align: center;">1200</p> <p style="text-align: center;">1400</p> <p style="text-align: center;">1600</p> <p style="text-align: center;">1800</p> <p style="text-align: left;">-19.4</p> <p style="text-align: right;">-7.5</p> <p>Repair</p>
SP 60	<p style="text-align: center;">F (mm) VV S08 - SP 113.10.60</p>  <p style="text-align: center;">200</p> <p style="text-align: center;">400</p> <p style="text-align: center;">600</p> <p style="text-align: center;">800</p> <p style="text-align: center;">1000</p> <p style="text-align: center;">1200</p> <p style="text-align: center;">1400</p> <p style="text-align: center;">1600</p> <p style="text-align: left;">-19.4</p> <p>Repair</p>

<p>SP 70</p>	<p style="text-align: center;">F (mm) VV S08 - SP 113.10.70</p> <p style="text-align: center;">Repair</p>
<p>SP 80</p>	<p style="text-align: center;">F (mm) VV S08 - SP 113.10.80</p> <p style="text-align: center;">Repair</p>
<p>SP 90</p>	<p style="text-align: center;">F (mm) VV S08 - SP 113.10.90</p> <p style="text-align: center;">Repair</p>
<p>SP 100</p>	<p style="text-align: center;">F (mm) VV S08 - SP 113.10.100</p> <p style="text-align: center;">Repair</p>
<p>SP 130</p>	<p style="text-align: center;">F (mm) VV S08 - SP 113.10.130</p> <p style="text-align: center;">Repair</p>

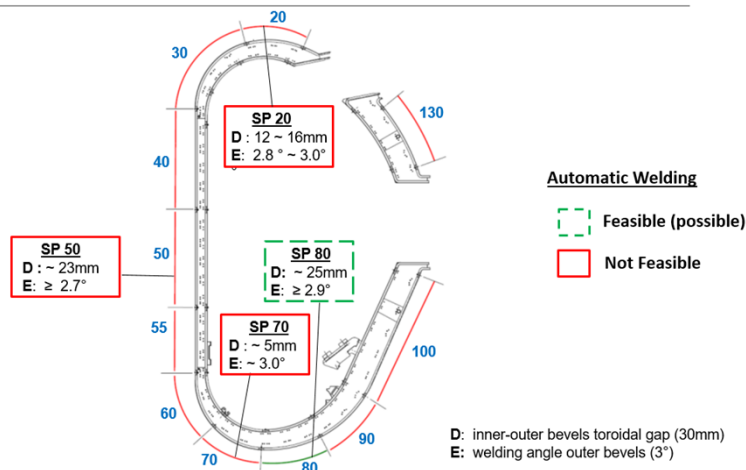
### A-4 Sector 8 facing sector 9

Figure A-4 show overall results on toroidal and bevel angle deviation for all splice plates

VV S08 – facing S09 (1<sup>st</sup> Batch)



VV S08 – facing S09 (2<sup>nd</sup> Batch)



VV S08 – facing S09 (3<sup>rd</sup> Batch)

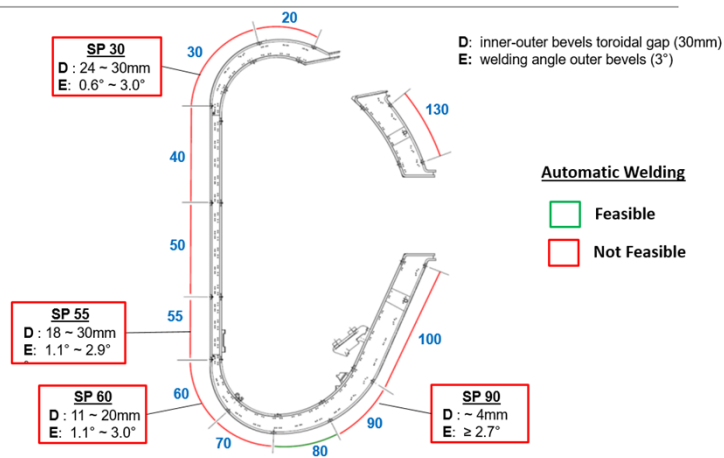


Figure A-4 Overall summary on toroidal and bevel angle deviation

Table A-4 Toroidal deviation only

Splice plate ID	Toroidal deviation profile
SP 20	<p style="text-align: center;">F (mm) VV S08 - SP 113.10.20</p> <p style="text-align: right;">-16.9</p> <p>Repair</p>
SP 30	<p style="text-align: center;">F (mm) VV S08 - SP 113.10.30</p> <p style="text-align: right;">-4.0</p> <p>Repair</p>
SP 40	<p style="text-align: center;">F (mm) VV S08 - SP 113.10.40</p> <p style="text-align: right;">-7.4</p> <p>Repair</p>
SP 50	<p style="text-align: center;">F (mm) VV S08 - SP 113.10.50</p> <p style="text-align: right;">-5.3</p> <p>USE AS IS</p>
SP 55	<p style="text-align: center;">F (mm) VV S08 - SP 113.10.55</p> <p style="text-align: right;">-6.5</p> <p>Repair</p>
SP 60	<p style="text-align: center;">F (mm) VV S08 - SP 113.10.60</p> <p style="text-align: right;">-13.9</p> <p>Repair</p>

<p>SP 70</p>	<p style="text-align: center;">F (mm) VV S08 - SP 113.10.70</p> <p>Repair</p>
<p>SP 80</p>	<p style="text-align: center;">F (mm) VV S08 - SP 113.10.80</p> <p>USE AS IS (if possible)</p>
<p>SP 90</p>	<p style="text-align: center;">F (mm) VV S08 - SP 113.10.90</p> <p>Repair</p>
<p>SP 100</p>	<p style="text-align: center;">F (mm) VV S08 SP 113.10.100</p> <p>Repair</p>
<p>SP 130</p>	<p style="text-align: center;">F (mm) VV S08 - SP 113.10.130</p> <p>Repair</p>

## Annex B Alternative Proposals for Repair

For large deviations in the toroidal direction as the one assessed for the lower segment of Sector 8 (see Table 7.3 Splice Plates 60 to 100), an alternative to build-up by machining of the sector edge and welding of an additional strip plate.

This concept is illustrated below:

